

CONTENTS

1. Terminology
2. Isolation
3. Safety
4. Filtering
5. Isolation capacitance
6. Partial discharge immunity
7. Limiting inrush current
8. Maximum output capacitance
9. Reverse polarity protection
10. No load output voltage
11. Pre-biased outputs
12. Output voltage trimming
13. Frequency synchronisation
14. DC-DC Converter performance measurement guideline
15. Derating guidelines
16. Board layout for DC-DC converters
17. Applications
18. Soldering information

1. TERMINOLOGY

The data sheet specification for DC-DC converters contains a large quantity of information.

This terminology is aimed at ensuring the user is interpreting the data provided correctly and obtaining the necessary information for their circuit application.

ABSOLUTE MAXIMUM RATINGS

The absolute maximum ratings are the limits to which the devices can be stressed without causing permanent and irreparable damage. These limits are not the normal operating or functional limits of the devices. Operating at the absolute maximum ratings may produce different parametric results to those quoted in the datasheet and reduced reliability/lifetime.

CONTINUOUS BARRIER WITHSTAND VOLTAGE

The continuous voltage that may be applied across an isolated DC-DC converter without damage or long term degradation. If the converter is used as a safety barrier, this is the continuous voltage that may be applied while maintaining the stated level of safety rating and is much lower than the continuous voltage for no damage.

DERATING

Murata DC-DC converters are rated to limit the maximum junction temperature of the internal semiconductors, or the magnetic material, being reached so that the lifetime of these parts is not degraded while the circuit is at maximum load and temperature conditions in a static air environment. This can mean that some converters have to be derated (i.e. operated at a slightly lower power loading) at elevated temperatures to prevent the internal temperatures exceeding these limits for the components. The effect can be reduced by having an air-flow over the DC-DC converter, hence removing the heat, and curves showing how much air-flow is required to reduce the internal temperature to reduce the derating is provided. These are static conditions; hence it may be possible to exceed the derating for a short/transient period with negligible impact on product lifetime.

EFFICIENCY

The ratio of power delivered from the device to power supplied to the device, expressed as a percentage, when the part is operating under specified conditions, typically nominal input and 100% load.

FAILURES IN TIME (FIT)

FIT (Failures in Time) is an industry standard calculated value defined as the Failure Rate (λ) per billion hours of run-time. FIT is sometimes easier to use than Mean Time To Failure (MTTF, see below). The reason for the preferred use for FIT is that simple positive numbers, such as 80 per billion hours, is more intuitive and easier to remember than MTTF values, such as 12.5 million hours.

INPUT RIPPLE CURRENT

Ripple current on the input to a DC-DC converter caused by its switching operation at high frequency. Typically specified as a peak to peak with a specified input impedance and measurement bandwidth.

INSULATION RESISTANCE

The resistance between input and output circuits of an isolated DC-DC converter. This is usually measured at 1000VDC.

INPUT TO OUTPUT ISOLATION (ISOLATION TEST VOLTAGE)

Normally a high voltage applied during production test across input to output of an isolated DC-DC converter to verify the integrity of insulation (hi-pot test). This voltage test should not be repeated unnecessarily or applied continuously. The continuous voltage rating is given elsewhere in the data sheet. The hi-pot test voltage may be related to any agency safety rating that the DC-DC converter holds. See definition 'CONTINUOUS BARRIER WITHSTAND VOLTAGE' and sections 'ISOLATION' and 'SAFETY APPROVAL'.

INPUT VOLTAGE RANGE

The range of input voltage that the device can tolerate and maintain functional performance.

ISOLATION CAPACITANCE

This is the total capacitance between the input and output of an isolated DC-DC converter, measured with the input pins shorted together, and the output pins shorted together. This is usually dominated by the interwinding capacitance of the transformer, but will also include any structural capacitance within the circuit or any capacitance from feedback components (e.g. opto-isolators).

1. TERMINOLOGY (Continued)

LIFE TIME

The average expected time across a large number of products during which a DC-DC product will meet its specification. If the product has components that have a 'wear-out' mechanism such as optocouplers or electrolytic capacitors, the lifetime may be far less than MTTF. The DC-DC may not fail completely at the end of its life and may still enable the end application to work if the DC-DC parameter degradation is not critical in that application (for example output voltage may be just below the minimum in the specification).

LINE VOLTAGE REGULATION

For regulated converters, the change in output voltage over the specified input voltage range expressed as a percentage of nominal output voltage. For example, if a 0.1V change in output voltage is measured on a 12V output device over the stated input voltage range, line regulation is 0.83%.

For non-regulated converters it is normally expressed as the ratio of the percentage change in output per percentage change in input at a fixed load. For example, on a 5V to 5V converter, if the input changes by 0.5V (10%), such as from 4.75V to 5.25V and the output changes by 0.55V (11%), such as from 4.75V to 5.30V, then the line regulation is 1.1.

LOAD TRANSIENT RESPONSE

The characteristic of a regulated DC-DC converter whereby the output voltage momentarily changes then falls back when a load current step is applied. The output voltage typically jumps positive for a decreasing load step and negative for an increasing load step. Peak voltage deviation is specified and also a settling time for the voltage to return within a stated percentage of its original value.

PROTECTION

Various types of protection against fault conditions either internally or externally to a DC-DC converter may be implemented:

Over Voltage Protection (OVP) is a mechanism whereby the output voltage from the DC-DC converter is prevented from exceeding a set value after an internal fault. The protection may also 'trip' if an external over-voltage is applied. The DC-DC converter may shut down completely requiring a re-start or enter a 'hiccup' mode where the output cycles on and off between zero and the OVP set point.

Over Current Protection (OCP) prevents a DC-DC converter from being damaged by excessive load current above the rated value. The DC-DC will typically exceed its temperature rating and a thermal sensor will shut the DC-DC down. The DC-DC may reset when the temperature falls to a lower temperature or may latch off completely requiring a restart.

Short Circuit Protection (SCP) prevents damage to the DC-DC when a short circuit is applied to the output. The DC-DC may recover when the short circuit is removed or may latch off requiring a restart. A short circuit at the end of long connections to the DC-DC output may not trip the SCP and protection of the DC-DC may then rely on OCP/OTP.

Over Temperature Protection (OTP) prevents components within the DC-DC converter exceeding their temperature ratings due to an overload or ambient temperature being over specification. The DC-DC converter may shut down completely requiring a restart or recover when the temperature falls significantly.

Under-Voltage Protection (UVP), or Under-Voltage Lock-Out (UVLO), is when a converter monitors the input voltage and prevents power conversion (i.e. no output) until the input voltage exceeds a minimum value; usually within or close-to the nominal operating conditions.

STORAGE TEMPERATURE

The temperature range over which the product may be stored, non-operating, without long term damage. Extended periods at high temperatures may cause some components such as electrolytic capacitors and optocouplers to degrade. DC-DC converter lead solderability may also be affected. To minimize the impact, recommendations for storage and packaging should be followed.

SWITCHING FREQUENCY

The nominal frequency of operation of the switching circuit inside the DC-DC converter.

TEMPERATURE DRIFT

The change in output voltage, expressed as a percentage of the nominal, per degree change in ambient temperature.

TEMPERATURE RISE ABOVE AMBIENT

The temperature rise developed by the device under full load conditions measured at a specified point.

TEMPERATURE DERATING

The reduction of maximum output power available from a DC-DC at higher or lower ambient temperatures normally shown as a graph for different conditions of input voltage and airflow. Some converters do not derate and give full power up to their maximum operating temperature (see DERATING).

2. ISOLATION

Isolation of DC-DC converters, that is no electrical connection between input and output, is used for several different functions which may be required alone or in combination. One function maybe be safety, see separate section 'SAFETY'.

GROUND ISOLATION

In any electrical system, ground currents naturally flow as signal or power returns. Sometimes, it is necessary to separate these currents so that they do not interact and produce noise or spurious operation. To help achieve this, an isolated DC-DC converter can be configured with 'single point grounding' so that its own load current flows back to itself directly and not necessarily through other grounds, reducing interactions. In one extreme, ground currents flow simply due to local differences in ground voltage, perhaps at two ends of a communications link. The current can be high enough to actually damage wiring so isolation of the signals with, for example, a data isolation IC and power with a DC-DC converter solves the problem. See Figure 1 for a typical RS232 isolated interface, or Figure 2 for an isolated CAN bus interface.

EMI ISOLATION

Modern data interfaces employ balanced signal transmission without a signal ground connection avoiding the risk of ground currents but there is still a risk that environmental EMI or lightning strike induced transients are picked up and coupled back into the system. If the communications link has isolation for signals, through a data isolation IC and for power through an isolated DC-DC converter, this risk is reduced. Similarly EMI generated by the system, conducting or radiating out along communications lines is limited by isolating the data and power. See Figure 3 for a typical RS485 isolated balanced data interface.

VOLTAGE RAIL GENERATION

A DC-DC converter can be used to locally generate extra voltage rails such as $\pm 15V$ from a system 12V or perhaps 5V from 3.3V as shown in Figure 4. Isolation may not be necessary in these circumstances. However, an isolated converter can be an easy way to generate another rail simply by the connection arrangement. Figure 5 shows various arrangements of connections that can generate higher voltages or negative voltages at low power. This may be far more cost effective than specifying a system supply with these rails as auxiliary outputs.

Figure 1: ISOLATED RS232 INTERFACE

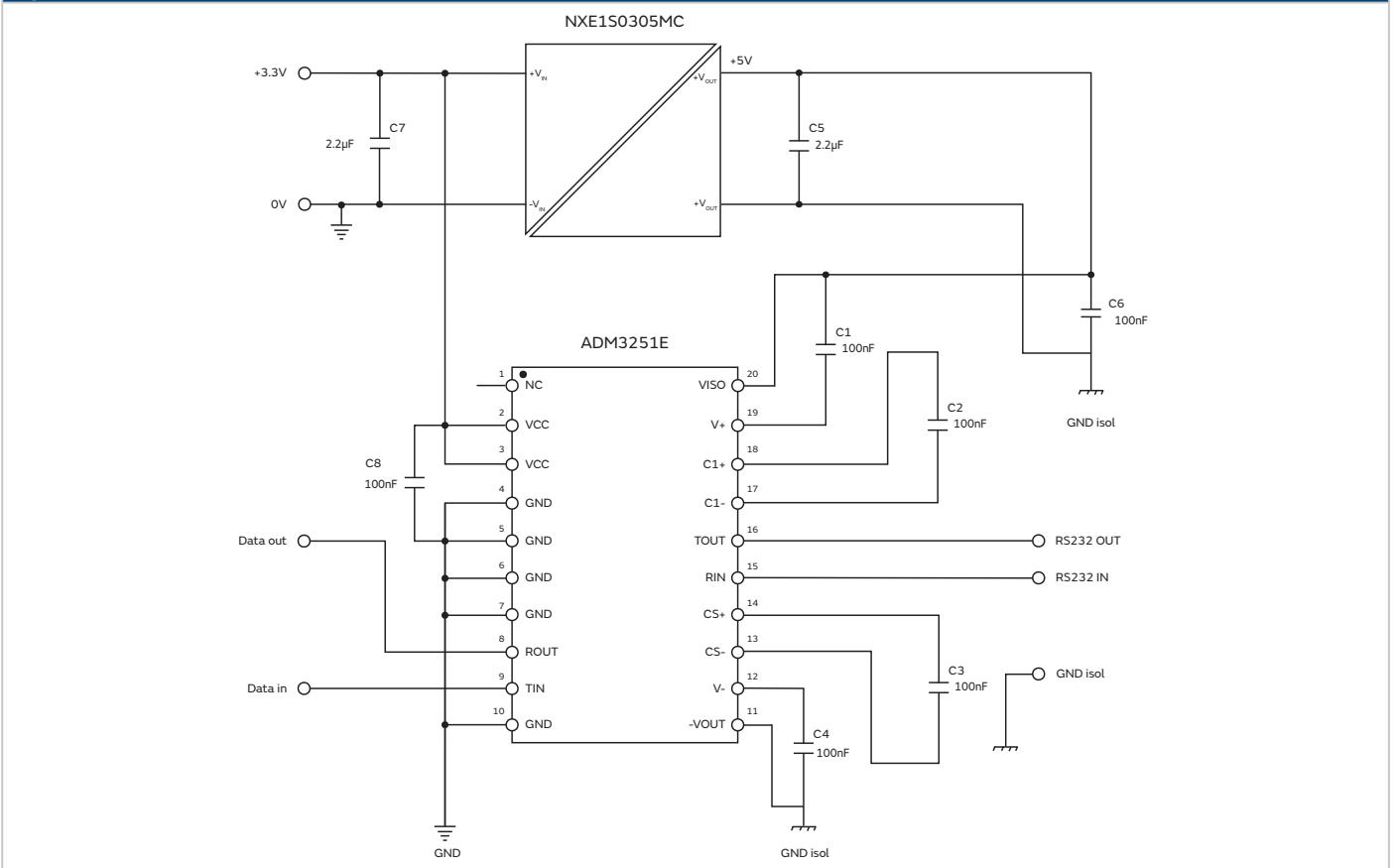

Figure 2: ISOLATED CAN BUS INTERFACE

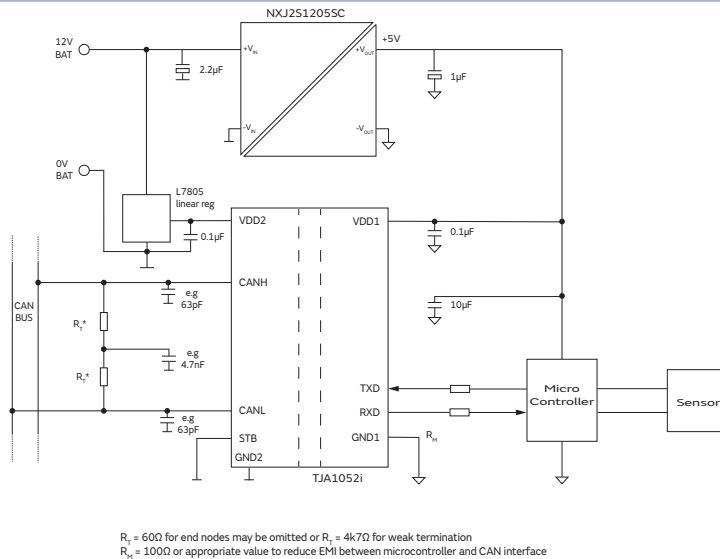

Figure 3: RS485 ISOLATION

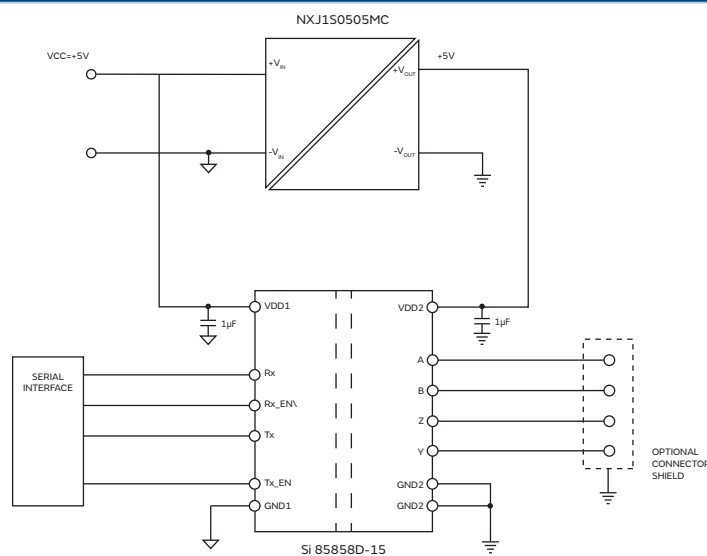
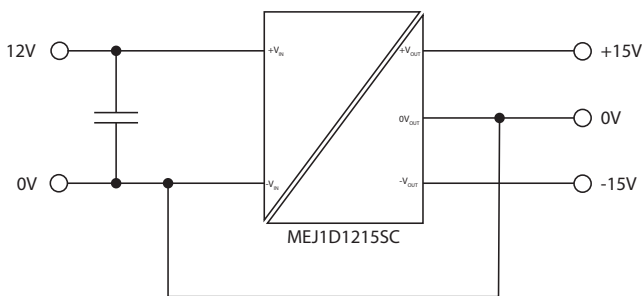
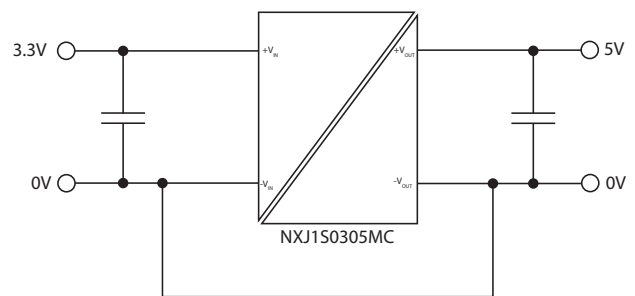

Figure 4: TYPICAL LOW POWER DC-DC NON-ISOLATED APPLICATIONS



Non-isolated ±15V from +12V input



Non-isolated +5V from +3.3V input

Figure 5: CONFIGURATIONS OF ISOLATED DC-DCs PRODUCING AUXILIARY VOLTAGES

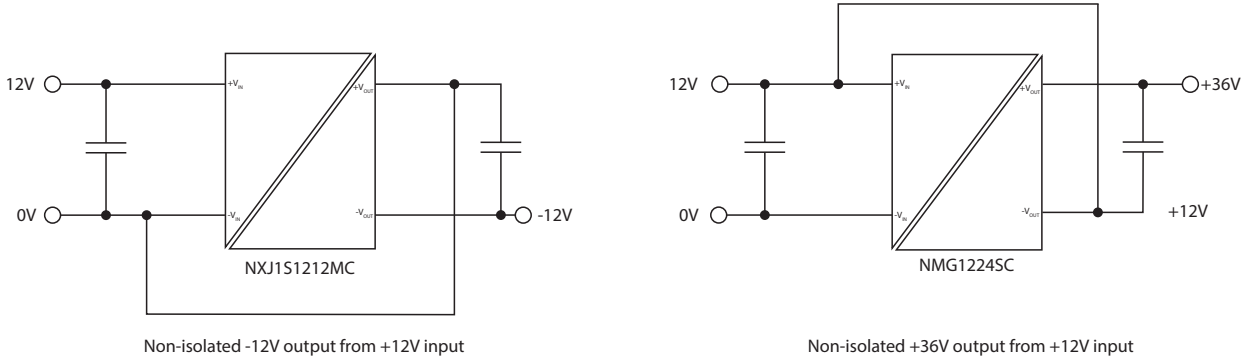

3. SAFETY

In many applications, a DC-DC converter requires isolation to provide a 'safety barrier' between its input and output. The input to the converter may only be low voltage but this could, for example, be 'referenced' to an unsafe mains voltage. An example would be a non-isolated 'buck' converter generating 5V from rectified mains for a low power application followed by a 5V to 5V DC-DC powering an isolated interface. See Figure 6. If an operator can touch the output connections of the DC-DC converter or the interface, a high level of approved safety isolation is necessary. Sometimes safety isolation is necessary to allow for fault conditions. If a single fault could put a dangerous voltage on the input to a DC-DC converter and an operator can touch the output, a minimum level of safety isolation is necessary in the converter. This can work in reverse as well, if a fault condition could put a dangerous voltage on the output of a converter and an operator could touch the input, again a level of safety isolation is necessary. Isolation in DC-DC converters can have various levels/strengths; see section 'SAFETY APPROVAL'.

SAFETY APPROVAL

As explained in section 'SAFETY' a defined level of isolation may be necessary in a DC-DC converter to protect an operator or user against electric shock. Generally, isolation that provides the minimum protection against shock is called 'BASIC' or 'ONE LEVEL OF PROTECTION' in the medical world. However, the minimum acceptable in a saleable product is higher, called 'REINFORCED', 'DOUBLE' or 'TWO LEVELS OF PROTECTION' for medical. This higher level can be achieved by combining a BASIC level with another physical level which is then called 'SUPPLEMENTARY'.

Isolation that physically provides no guarantee of long term integrity is called 'FUNCTIONAL' or 'OPERATIONAL'.

Isolation between input and output connections can be achieved in various ways; by physical separation of primary and secondary through air (clearance), separation along a surface in air (creepage), separation through a substantial solid material or through multiple solid layers of thin material. The various methods can be combined in one converter or across several converters to give a higher level of protection. The distances of creepage and clearance and through material are all defined by safety standards. The standards take into account the potential dangerous voltage level, (system voltage), the pollution degree of the environment, the possibility of transient voltages on the system voltage (over-voltage category), altitude and the general operating environment. For example medical safety standards define different strengths of isolation depending on whether the equipment is close to or away from a patient, requiring measures of operator protection (MOOPs) or measures of patient protection (MOPPs). Standards for different categories of equipment such as telecommunications or bench test equipment may have different values for creepage and clearance as well as distance through insulation, otherwise operating in the same conditions. Standards however are tending to converge in their requirements.

To be meaningful, a statement that a DC-DC converter meets a safety standard must include the level of protection; basic/supplementary/double/reinforced/MOOP/MOPP and the system voltage that applies. The declared level of isolation voltage does not necessarily relate to the safety approval level. A part with a production test voltage of 3kV may only have a functional level of safety isolation. The 'functional' 3kV test rating in this instance is a measure of how robust the barrier is against voltage transients causing converter damage and gives absolutely no guarantee of protection against electric shock. If no level of safety isolation is stated, it must be assumed that the isolation of the DC-DC converter is only functional.

FUSING

If over-stressed, a common failure mode of low power DC-DC converters is for their power transistors to go short circuit allowing a very high input current. If the input supply is not current limited in some way, the current could cause damage to other components or tracking or even the risk of fire. In this case an input fuse is recommended. Where DC-DC converters hold safety agency recognition or approval, the approval may be conditional upon an input fuse being fitted. If this is the case, the fuse rating is given in the DC-DC converter datasheet.

3. SAFETY (Continued)

MAXIMUM CONTINUOUS VOLTAGE BARRIER RATING

In most applications, low voltage DC-DC converters have minimal continuous voltage across their isolation barriers. A common application is to simply break a ground connection with the isolation so ground currents do not circulate. Another is to provide a barrier to EMI in an isolated data interface. In both cases the continuous voltage across the barrier may be close to zero. If no safety rating is required for the barrier in the DC-DC converter, parts with a FUNCTIONAL safety rating can be used. (See section SAFETY).

If the DC-DC converter is used for its safety rating, that is, it may have a dangerous voltage on its input or output that needs isolation, then a safety recognised/approved part will be specified. This part will have specified in its datasheet what 'system' or continuous voltage may be applied across the isolation barrier while maintaining its safety rating.

Parts with a FUNCTIONAL safety rating may be able to withstand continuous high voltages across their barrier but there must be other ways external to the DC-DC converter to prevent electric shock from these high voltages, particularly in the event of the DC-DC converter barrier failing short circuit. The reliability of the isolation barrier with high continuous voltages for devices with only functional isolation is not guaranteed and will closely depend on the actual voltage applied, AC or DC and if AC, what frequency and wave shape. For this reason FUNCTIONAL isolation devices are not recommended for this application. Murata has DC-DC converters, the MGJ series, designed specifically for applications with high continuous AC barrier voltages such as are found in 'high power' gate drives.

LEAKAGE CURRENT

AC line frequency leakage current is not normally an issue with low power DC-DC converters but there are some applications where it must be minimised such as when the input DC is derived from a non-isolated AC/DC converter as shown in Figure 6. In this application, a high isolation DC-DC converter is normally used which has very low coupling capacitance, with negligible contribution to leakage current. Theoretical leakage current (I_L) can be calculated from:

$$I_L = AC \text{ line rms voltage} \times 2 \times \pi \times \text{Line frequency} \times \text{coupling capacitance}$$

Hence with a 60Hz line frequency at 115VAC ($V_{rms} = 81V$), the leakage current is for the NXJ1S1205MC (2.5pF isolation capacitance):

$$I_L = 81 \times 2 \times \pi \times 60 \times 2.5 \times 10^{-9} = 76\mu A$$

At 230VAC (162Vrms) at 50Hz

$$I_L = 162 \times 2 \times \pi \times 50 \times 2.5 \times 10^{-9} = 127\mu A$$

Figure 6: DC-DC USED FOR REINFORCED SAFETY ISOLATION

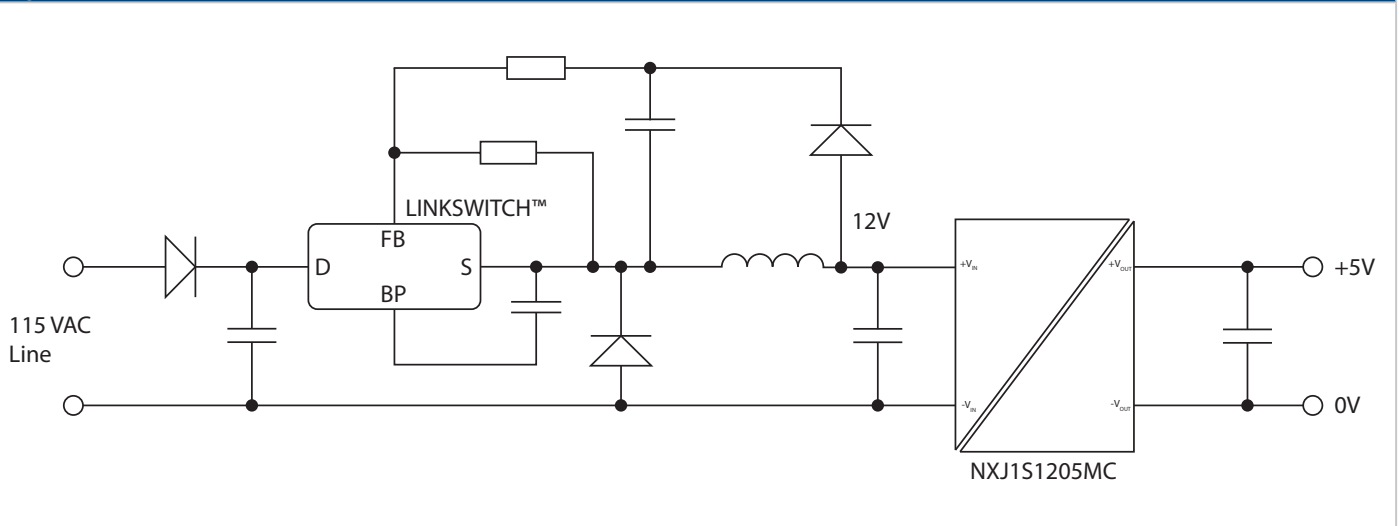

4. FILTERING

Input and output conducted ripple and noise from DC-DC converters can be reduced with filter networks - normally combinations of inductors and capacitors. All filters will degrade the DC-DC performance in some way so filtering should only be incorporated when absolutely necessary. Degradation that can occur is loss of efficiency, reduced accuracy of output voltage and worsened load transient response. In extreme cases input or output filters can cause DC-DC converter instability.

NOISE TYPES

Conducted noise can be of two types which may be present together: 'differential (series) mode' or 'common mode'. Differential mode noise on the output is measured from line to line in millivolts, peak to peak or rms. Differential mode noise on the input is typically measured in milliamps peak to peak or rms into a given upstream impedance. Common mode noise is measured from either input or output line to local ground as dB μ V into a termination of 50 Ω . As common mode noise circulates outside of the DC-DC through ground, there are statutory limits which can apply. There are no statutory limits for differential mode noise although note that the standard method for measuring noise to CISPR-22 using a line impedance stabilisation network (LISN) indicates a combination of differential and common mode noise.

FILTERS

Differential mode filters are typically LC networks on input or output see Figure 7. Datasheets for individual products may include recommended values to reach a given low noise level. See Figure 8 for typical 'before' and 'after' plots for output filtering. If other components are selected, choose the resonant frequency of the LC combination $1/2 \times \pi \times \sqrt{LC}$ to be about one tenth of the datasheet switching frequency with as small an inductance as practical. Larger inductor values are more expensive, give voltage transients with load steps and may have higher DC resistance, worsening efficiency and regulation. The self-resonant frequency of the inductor on its own should be as high as possible, beyond which the impedance starts to drop, reducing noise attenuation. The inductor should be chosen so it does not saturate at the maximum current flowing. Remember that at the 'rated' current of an inductor, its inductance value may have dropped considerably so a margin should be incorporated. Drum core type inductors will normally be the lowest cost option but their open format can cause radiation and noise pick-up. Toroidal types are better in this respect but are more expensive. The capacitor should have a low ESR. Parallel combinations of electrolytic and ceramic types can give best performance over a wide frequency range. If the DC-DC converter has remote sensing, do not connect the sense leads to the load side of a series filter as instability may occur.

Input series mode filters should have an output impedance much lower than a following regulated DC-DC converter input impedance to avoid converter instability. An extra damping network may be necessary in some cases to avoid this effect; components R and series capacitor shown in Figure 9. Unregulated converters do not suffer from this effect but damping may still be necessary to avoid 'ringing' of the input voltage with step changes. In extreme cases ringing can reach a damaging voltage for the DC-DC converter input.

Multiple stages of LC filtering can be included but are not normally necessary at low power.

Common mode filters take the form of 'common-mode' or 'current compensated' chokes and capacitors to ground. See Figure 10.

Common mode chokes pass the power and return supply lines together on separate windings with the windings phased such that the magnetic field cancels, as indicated by the 'dot' notation in the diagram. Because the field is cancelled, there is no effective inductance and impedance in the path of the normal running current and differential mode noise. Common mode noise however sees the full winding inductance and is attenuated. The capacitors are placed at the DC-DC terminals as the noise tends to be in the form of a current source and the capacitors in this position short the noise directly, the choke then blocks any residual noise.

There may be a limit to the total capacitance value of C1 and C2 allowed if the primary or secondary of the DC-DC converter is at AC line potential or can be, under fault conditions. This is to limit AC line leakage current. If this is the case the capacitors may need to be safety rated, Y1 or Y2 type.

Common mode noise can be prevented from circulating in ground externally to the DC-DC converter by adding C3 which circulates it locally. As noted above, this may need to be a safety rated component depending on the application and if fitted effectively increases the coupling capacitance of the converter, degrading its ability to isolate transients from one side of the converter to the other.

The common mode chokes can be wound with deliberately less than perfect coupling between the windings. This effectively adds in some series mode (uncoupled) inductance which can attenuate series mode noise. This is a useful way to minimise total number of components.

Figure 7: INPUT AND OUTPUT DIFFERENTIAL MODE FILTERING

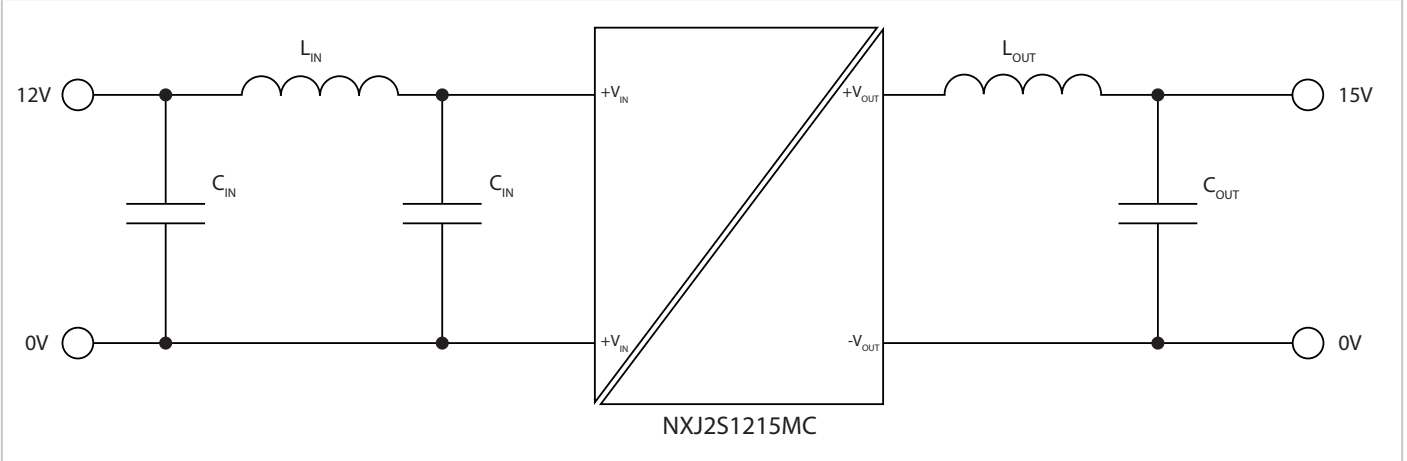

Figure 8: OUTPUT NOISE BEFORE AND AFTER FILTERING

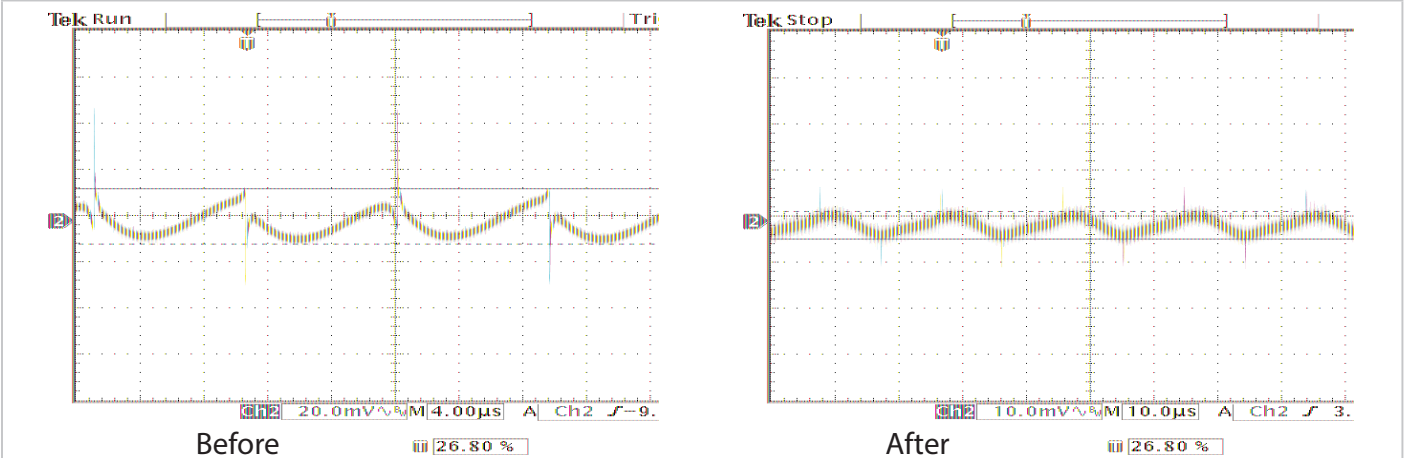

Figure 9: DAMPING OF INPUT FILTER

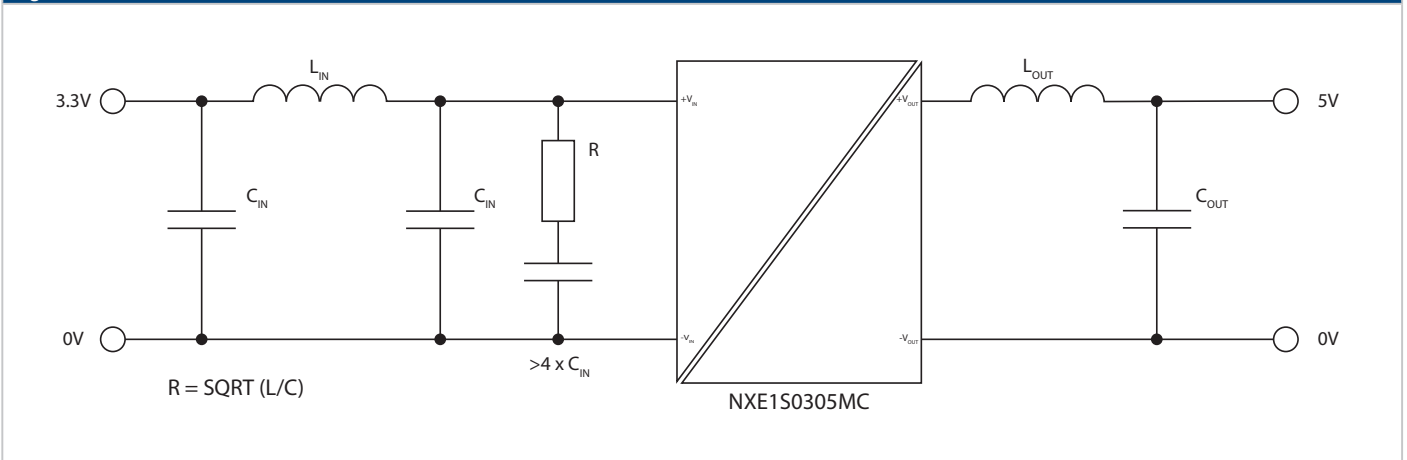
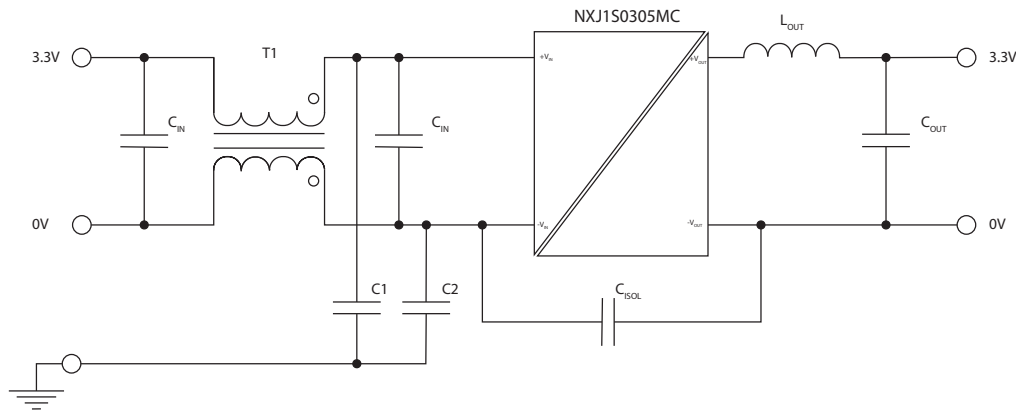

Figure 10: INPUT COMMON MODE FILTERING



4. FILTERING (Continued)

NOISE MEASUREMENT

Measurement of true differential mode output noise can be difficult in the presence of radiated noise and common mode noise. For example oscilloscope probes pick up radiated noise in the loop formed by their probe ground lead and measurement tip and show it as differential noise as shown in Figure 11. A more accurate method is to disconnect the probe ground clip and use the probe earth ring as the reference as shown in Figure 12. Murata uses a standardised test method in product qualification shown in Figure 13 to avoid measurement uncertainty. Note that the oscilloscope displays a tenth of the actual noise level.

Input noise level is measured with a current probe with a specified series inductance typically 12µH see Figure 14.

Input noise is measured using the standard test method to CISPR-22 using a Line Impedance Stabilisation Network (LISN) as shown in Figure 15. Defined limits for input noise are given for example in standards EN55032 or FCC 0871. Low power DC-DC converters typically need an external filter to meet the most severe limits (curve B). Note that these standards were written primarily for AC/DC converters that connect directly to the AC line and there is no statutory requirement for DC-DC converters as components within a system to meet these standards. The standard limits are therefore used only as a relative reference for the performance of Murata low power DC-DC converters. Figure 16 shows noise performance of a typical Murata low power DC-DC converter with its recommended filter.

The LISN measures effectively the sum and difference of the differential and common mode noise on the DC-DC converter input lines so normally both modes of noise need to be suppressed to give a comfortable pass below the standard limit lines.

Most concern about common mode noise is related to the input of DC-DC converters. Outputs however also show common mode noise. This can be attenuated in the same way with common mode chokes and capacitors to ground as shown in Figure 17.

Any radiated EMI from low power DC-DC converters usually originates from conducted EMI on the converter input and output lines. This is directly affected by external circuit layout and customer filtering. Because of this, radiated EMI is not normally characterised in low power DC-DC converter data sheets but will be minimised by the conducted EMC filtering guidelines given. Some converters have metallic cases which normally connect internally to the output return line. This assists in EMI shielding.

Figure 11: INCORRECT WAY TO MEASURE DIFFERENTIAL NOISE

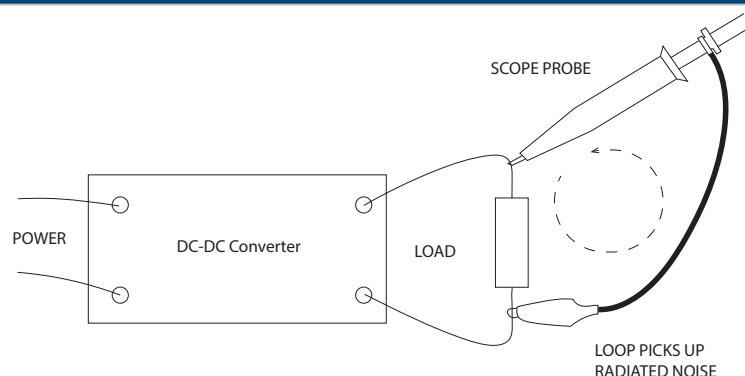

Figure 12: CORRECT WAY TO MEASURE DIFFERENTIAL NOISE

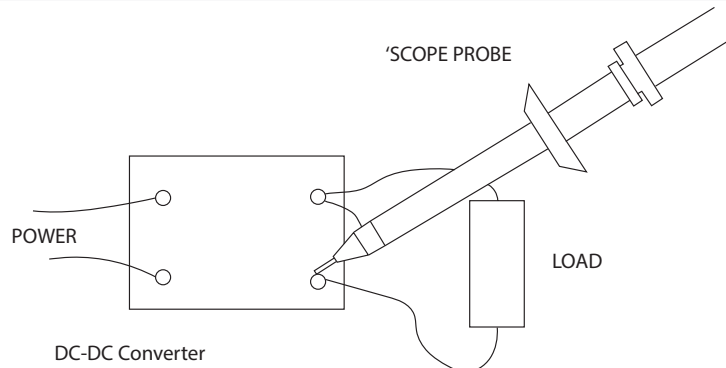

Figure 13: OUTPUT RIPPLE AND NOISE CHARACTERISTICS

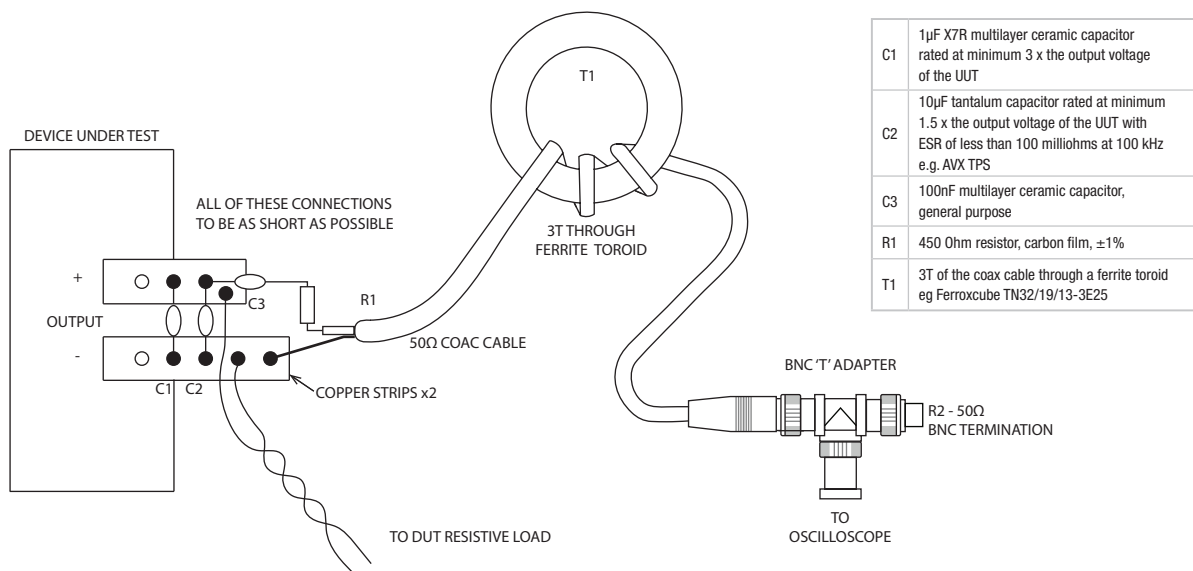
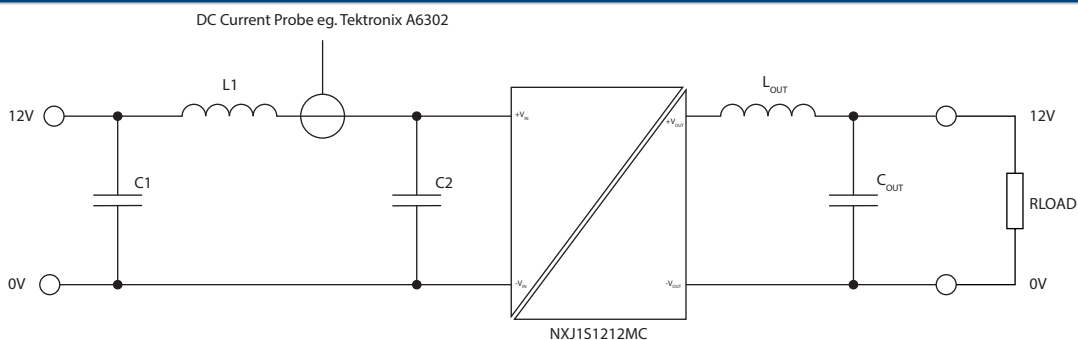

Figure 14: STANDARDISED TEST METHOD FOR INPUT RIPPLE CURRENT



C1 - 220μF with ESR of <0.1Ω at 100kHz, rated at supply voltage.

C2 - The recommended value for the product. If none is recommended, use 47μF with ESR <0.7Ω at 100kHz, rated at supply voltage.

L1 - 12μH rated at the 150% minimum of the DC current taken by the converter.

Figure 15: STANDARD COMMON MODE NOISE TEST SETUP EN55022

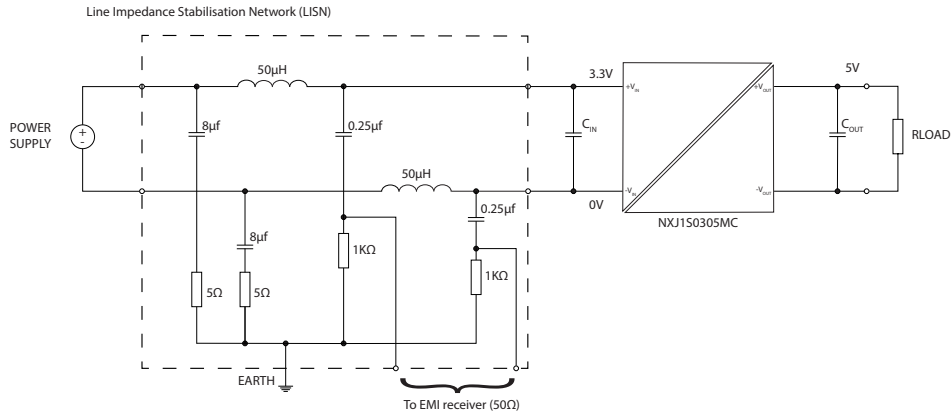

Figure 16: TYPICAL EMC PLOT

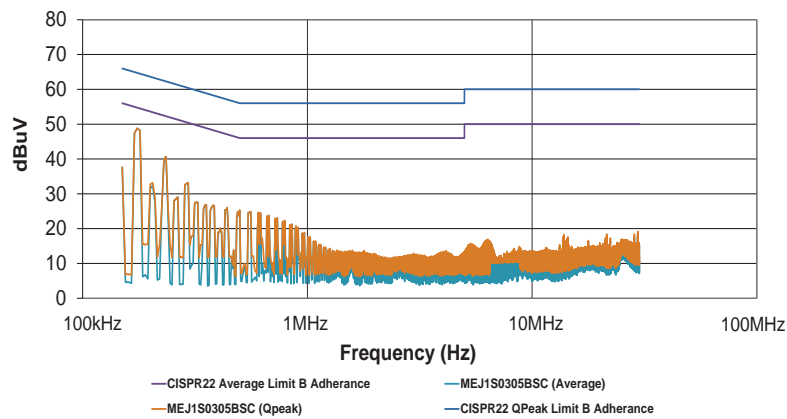
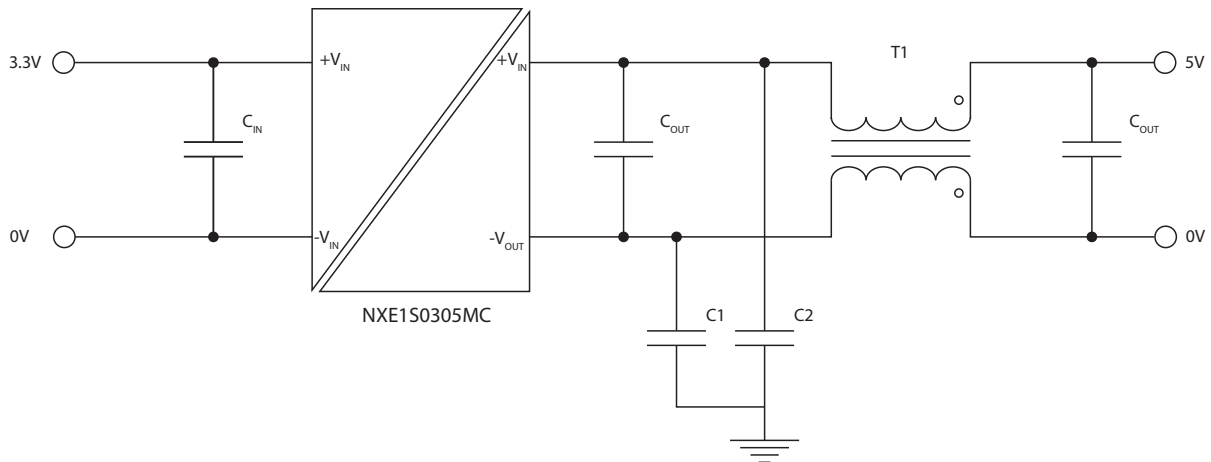

Figure 17: OUTPUT COMMON MODE FILTERING



5. ISOLATION CAPACITANCE

Isolated low power DC-DC converters have input-output capacitances from a few pF to hundreds pF depending on model. This capacitance is formed mainly from coupling capacitance in the transformer with contributions from any feedback optocoupler used and circuit board strays. Low capacitance helps to isolate transient voltages on input or output from crossing the isolation barrier. Also if the DC-DC is used in applications where there is continuous AC across the barrier such as in 'high-side' gate drives, the low capacitance minimises displacement current through the barrier and maximises immunity to the transient switching (dV/dt) of the AC waveform.

6. PARTIAL DISCHARGE IMMUNITY

Partial discharge is the slow effect of cumulative breakdown of microvoids in insulation systems eventually leading to complete failure. Typically the effect starts at a particular 'inception voltage' and stops again at a lower 'extinction' voltage. The actual voltages vary with the detail of the particular insulation system and are usually in the kilovolt range. Some worst case results for example Murata low power DC-DC converters are given in Figure 18. It can be seen that devices with only functional isolation such as NCS6 have low inception and extinction voltages even though their production hi-pot test voltage may be higher. Parts designed specifically for high continuous barrier voltage operation such as the MGJ series show best results.

Figure 18: PD COMPARISON

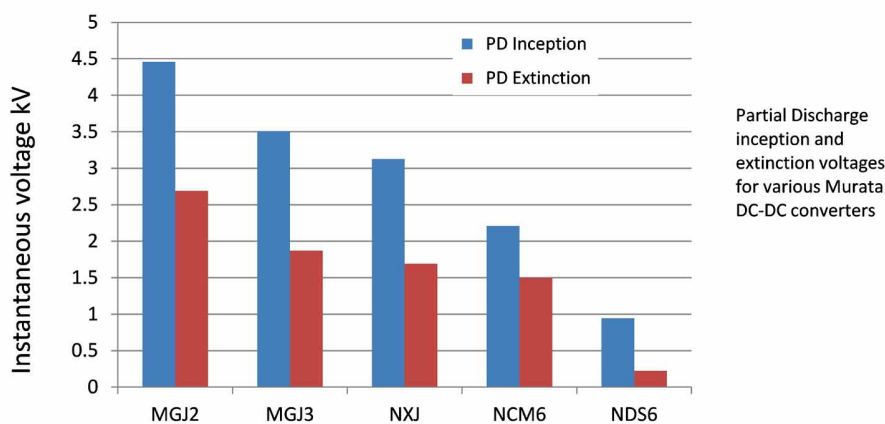

7. LIMITING INRUSH CURRENT

Most low power DC-DC converters have relatively small input capacitors which do not take significant inrush surge energy. However some converters do take an inrush surge into their power components due to their conversion topology. These high inrush current converters can 'latch up' into a non-operational state if the input is applied very abruptly such as through a mechanical switch. A series inductor on the positive input line as shown in Figure 7 can alleviate both effects (inrush and latch-up), while also reducing EMI. Series resistance can also be added, but degrades efficiency and in the case of non-regulated converters, degrades output voltage accuracy.

8. MAXIMUM OUTPUT CAPACITANCE

Low power DC-DC converters often have a maximum output capacitance stated. This is for fast and reliable start-up across the operating temperature range. The value is conservative and will depend on the actual capacitor type and how its parameters such as capacitance and Equivalent Series Resistance (ESR) change over temperature.

9. REVERSE POLARITY PROTECTION

Some low power DC-DC converters will take a large input current if the input supply is reversed. A series input diode will protect against this. If the voltage or power loss is not tolerable with a series diode, a shunt diode can be fitted with a series fuse as shown in Figure 19. If the diode is a Zener type, it can also give some protection against input voltage transients. Another option is a series P channel MOSFET connected as in Figure 20. The device can be chosen for low Rds(on) giving low voltage drop. Alternatively an N-channel MOSFET could also be used in the negative input line.

Figure 19: A SHUNT ZENER DIODE GIVES REVERSE POLARITY AND TRANSIENT PROTECTION

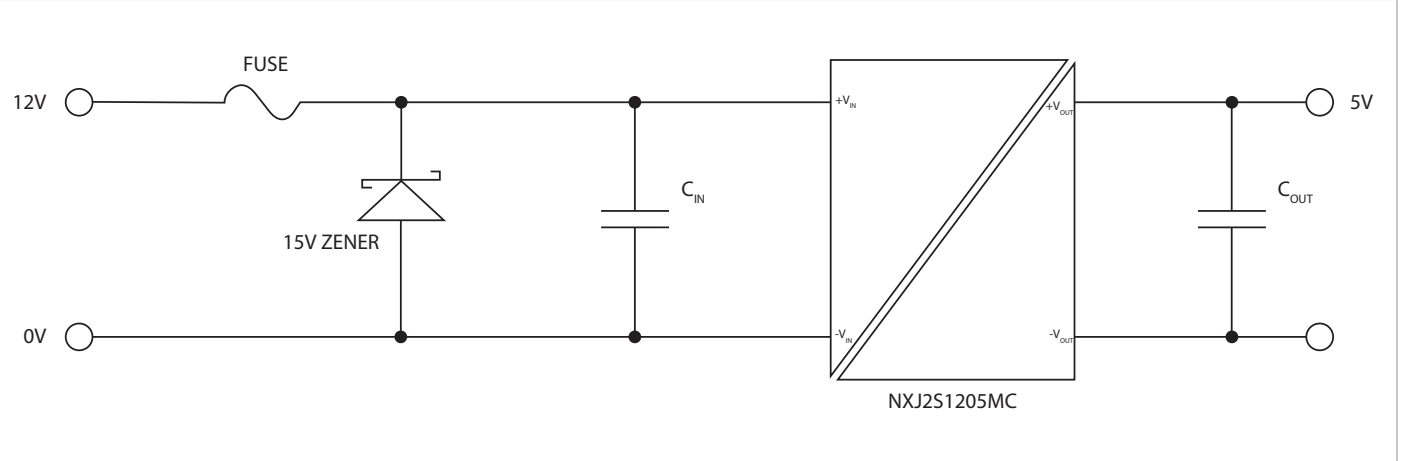
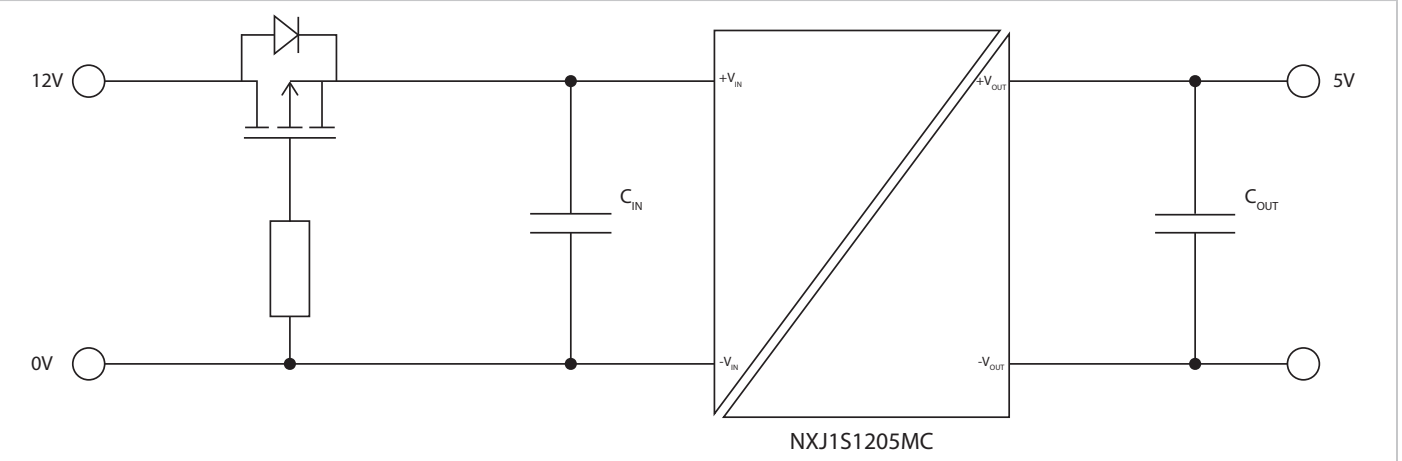

Figure 20: P-CHANNEL MOSFET GIVING REVERSE POLARITY PROTECTION



10. NO LOAD OUTPUT VOLTAGE

Unregulated low power isolated DC-DC converters may not have any active limiting of their output voltage and require a minimum load for the output voltage remain within specification. The minimum load is typically 10% of full load, but the individual device datasheets should be consulted to confirm.

If the load is less than 10%, the output voltage will exceed the maximum in the specification, and this may be problematic for the application circuit. If this is problematic a dummy load should be fitted to the output to maintain at least 10% load, or a minimum load that maintains the output voltage within the tolerance of the application circuit. The simplest would be a resistor across the output, however, this then reduces the maximum current available as 10% is always utilised by the dummy load, so in some circuits this means only 90% of power available for the actual application itself.

If the loss in a dummy load is unacceptable, a Zener diode can be fitted to clamp the voltage and selected to match the output voltage required. The Zener will require a current limiting resistor to prevent excessive load and over-heating of the diode itself. The resistor should be chosen to limit the maximum acceptable voltage at 10% load. For example, in Figure 22, with a 15V output assuming the maximum voltage excursion is 16.5V, then a 220R resistor and 15V Zener allows the 6.8mA (approximately 10% load) to pass through the Zener while limiting the voltage excursion. When the external application circuit load begins to draw current, the unregulated output voltage will fall and at around 15V output the Zener will stop conducting, typically this happens around 60% load, and the whole of the DC-DC converter power will be available to the application, hence none is lost in the dummy load.

This circuit can be further improved by use of a transistor current bypass controlled by the Zener, this offers a tighter control of the output voltage without risking over-stressing the Zener diode (limited to approximately 12.7V in the circuit shown in Figure 21). Hence the output can be regulated on the higher side to ensure lower voltage stress on the application circuit, but again without loss of available current at high load as the transistor switches-off once the load reaches around 40-50% of maximum output and the Zener itself only consumes around 150µA of current.

Figure 21: AUTOMATIC PRE-LOAD CIRCUIT 15mA

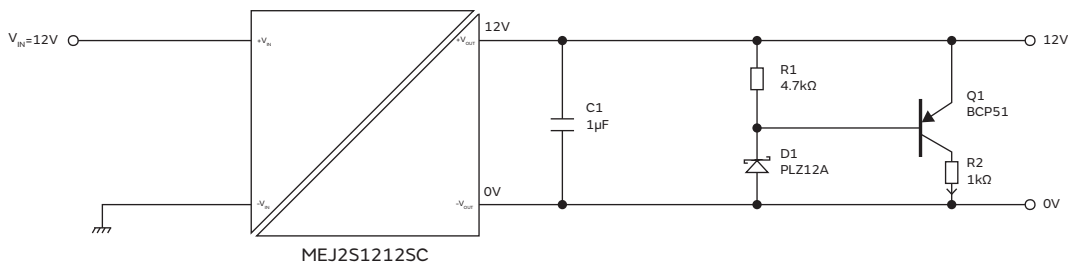
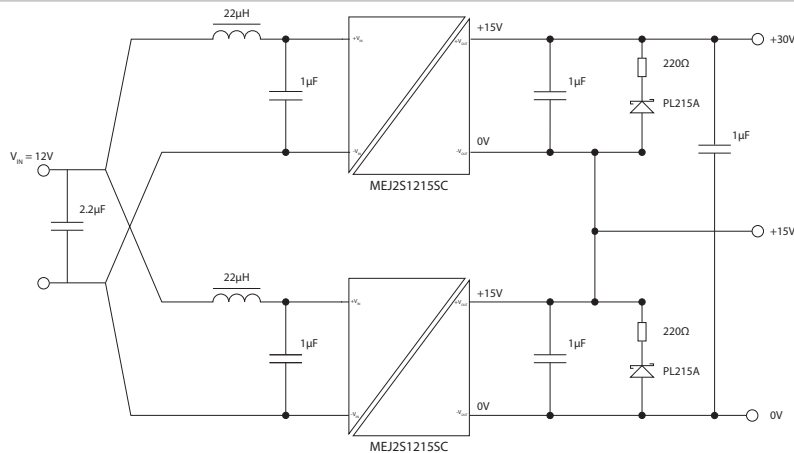

Figure 22: PROTECTION DIODES ACROSS SERIES CONNECTED OUTPUTS AND FILTERING PARALLELED INPUTS



11. PRE-BIASED OUTPUTS

Under some circumstances, in real systems, DC-DC converters may be required to start with an external voltage imposed on their outputs. This may be from previously charged capacitors or from other system supply rails 'leaking' back on to the output. When 'synchronous rectification' using MOSFETs is used, there is a potential that current is sunk into the DC-DC converter output into a MOSFET during the start-up period causing damage. This is called a 'pre-biased' condition. Generally, low power isolated DC-DC converters from Murata use simple diode rectification on their outputs and the problem does not occur. However, if DC-DC converter outputs are put in series, anti-parallel diodes should be included across each output as mentioned in section 17 'CONNECTING DC-DC CONVERTER OUTPUTS IN SERIES' to avoid negative voltage pre-bias causing problems (see Figure 22).

12. OUTPUT VOLTAGE TRIMMING

Most simple low power DC-DC converters do not have a voltage trim function. This is available however in some low power regulated parts from Murata. When used, datasheet guidelines should be followed. Note that these converters may have an over voltage protection circuit and trimming the voltage upwards may produce nuisance over voltage shutdown especially on load transients. Total rated power loading should not be exceeded. For example, if the output voltage is trimmed upwards by 10% of nominal, the maximum output current should be derated by about 9% to maintain the same power loading. Trimming the output voltage down is not guaranteed to allow higher current loading as components may be stressed at the higher current irrespective of power loading.

Where a trim function is available, it can be activated by an external resistor to the positive or negative output according to a trim equation given in the datasheet. Normally an external voltage can also be applied to the trim pin to adjust the output. Any noise on this connection will be translated to noise on the converter output so the connection should be well decoupled.

The output trim function may be used with an external circuit to provide other functions such as remote sensing or active current sharing between converters. Figure 23 shows a conceptual circuit for active current sharing. Note that there is just a single 'P-Link' connection between the converters. The circuit is a guide only as the actual implementation depends on the programming equation of the trim pin.

Figure 23: ACTIVE CURRENT SHARING USING TRIM FUNCTION

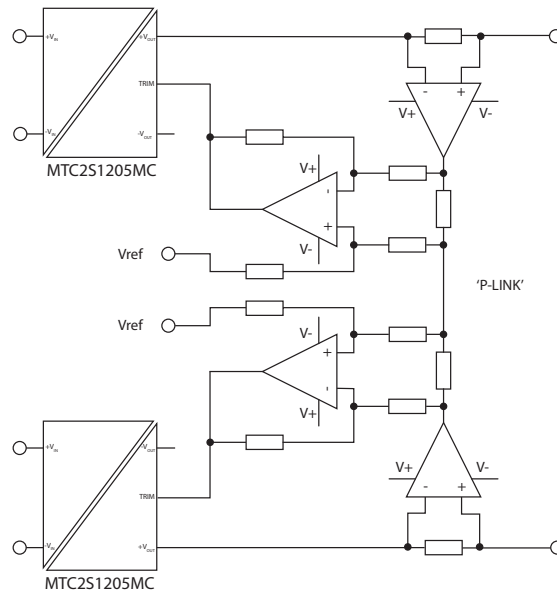

13. FREQUENCY SYNCHRONISATION

Some low power DC-DC converters available from Murata have the ability to have their internal oscillators synchronised with an external clock. This is often done to lock the DC-DC internal clock to a system clock for better predictability of EMI. With multiple DC-DCs, their oscillators can be synchronised with a deliberate timing offset to 'spread' the EMI signature for better results against required emissions standards. It is also possible to 'dither' or 'jitter' the frequency of the synchronising signal for a lower EMI signature. Figure 24 shows the effect on EMI signature for a MGJ series product with and without dithering, showing a useful improvement. Typically a logic level input to the DC-DC is required and the frequency can be synchronised within a small range. Traditional DC-DC clocks can only be synchronised to a higher frequency external clock but products such as the MGJ3 and MGJ6 series can be locked to lower or higher frequencies. The product datasheet should be consulted for the limits to the synchronisation feature.

Figure 24: BEFORE AND AFTER PLOTS OF 'DITHERING'

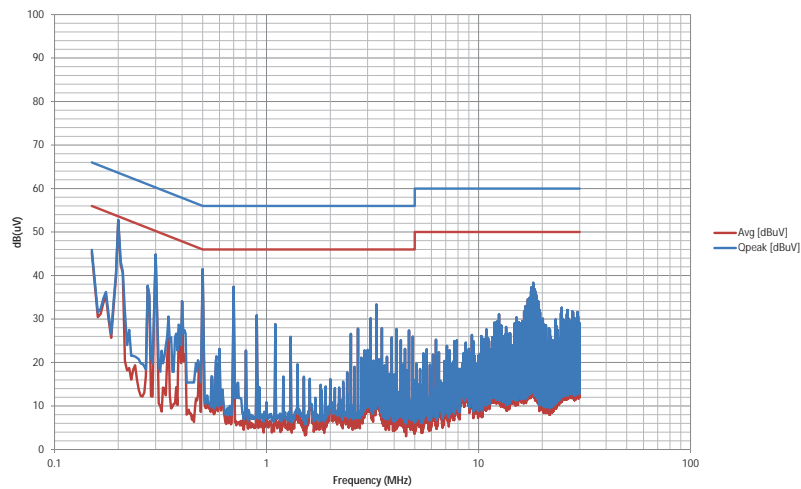

Without dither

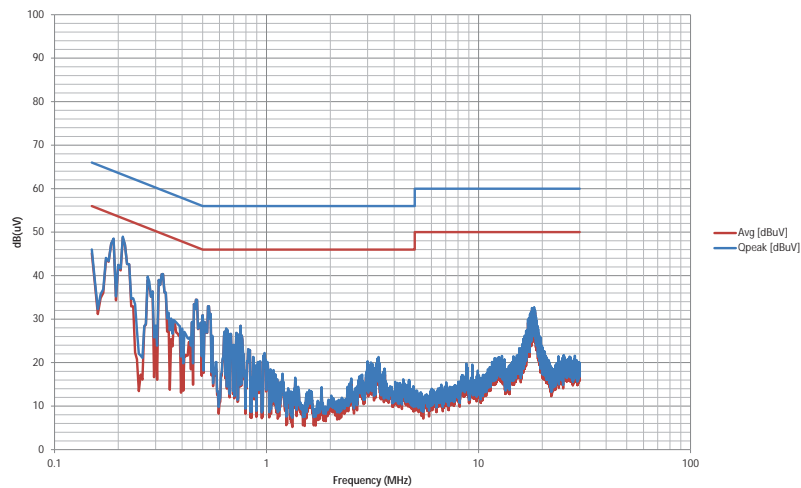

With dither

14. DC-DC CONVERTER PERFORMANCE

LINE REGULATION

Line regulation is the variation in percentage from nominal output voltage as input is varied over the allowable range. The figure is typically very small, around 0.1% for a regulated converter and around 1.2%/ for an unregulated converter. The efficiency of the converter is likely to change over the input range so time should be allowed for the converter to thermally settle before taking measurements. Equally, EMI, output ripple and noise may change over the input range so the output voltage measurement should be suitably filtered to show only DC changes.

LOAD REGULATION

(Static) load regulation is the variation of output voltage with load. For both unregulated and regulated converters, there will normally be a minimum load specified; typically 10% and load regulation should be measured from this value to 100% load. For unregulated converters, it is possible that the output voltage goes substantially higher at less than the minimum load. For regulated converters, this is less likely but in some cases the converter might enter a pulse skipping mode to keep the average output voltage correct. This can confuse meters used to monitor voltage.

In Murata datasheets, load regulation is given as a maximum % change of output voltage between the minimum and maximum load levels. Other datasheets might show seemingly better figures but these might be \pm values which are less meaningful.

As with line regulation measurements, the converter will certainly dissipate internally more or less power as the load is varied so it should be allowed to thermally settle between measurements.

Output ripple and noise is highly likely to change between load extremes so measurement equipment should be filtered effectively to avoid misleading results. Load regulation is normally measured with input voltage at its nominal value.

LOAD TRANSIENT RESPONSE

DC-DC converters have static load regulation which is the amount that the output voltage drops or rises with a change in load current. The voltage change persists if the load current change persists. Regulated DC-DC converters also have transient load regulation characteristics where the output voltage deviates by a larger amount for a short time as load current changes. The voltage then settles to the 'static' load regulation value. See Figure 25. The effect is caused by inevitable delays in the converter control loop causing the voltage to over or under-shoot the regulated value. The amount of over or under-shoot is affected by input voltage, load current and any added output capacitance or inductance. The recommended maximum output capacitance should be followed as noted in the converter datasheet. Note that LC filters added to the converter output will reduce switching ripple and noise but will normally worsen load transient response as load steps will cause voltage steps across the inductor.

When measuring load transient response, care should be taken. If an oscilloscope is used with AC coupling, it will display what looks like a slow voltage transient if the converter has less than perfect static load regulation. The change in static output voltage with a load step is charging and discharging the AC coupling capacitor on the oscilloscope input showing as a slow voltage transient. Ideally the oscilloscope should be used with DC coupling to avoid the effect. However, care should be taken not to set high sensitivity and exceed the scope input voltage range leading to inaccurate measurements.

Figure 25: LOAD TRANSIENT RESPONSE

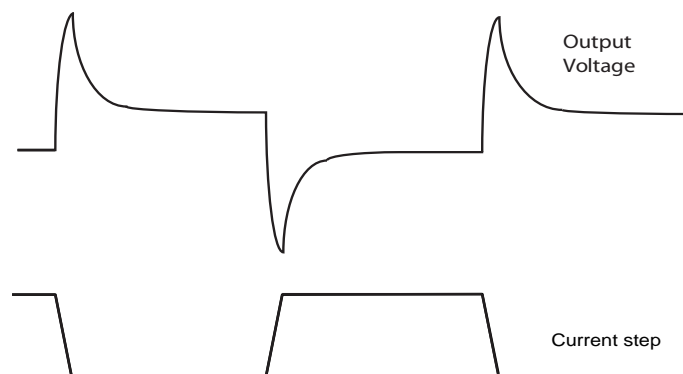

14. DC-DC CONVERTER PERFORMANCE (Continued)

EFFICIENCY

Efficiency is a measure of the power loss within a DC-DC converter. Nominal input and maximum load conditions are normally used. As efficiency rises, the measurement accuracy of voltage and current becomes more critical. For example, a converter which produces 5V and 1A with an input at 12V taking 0.58A has an efficiency of around 72%. If the accuracy of current measurement on input and output is $\pm 2\%$ then the efficiency measured is between 74.7% and 69%. If the DC-DC converter was more efficient and only took 0.44A on the input with an actual efficiency of 95%, with the same meters, the measured value would be between 98.6% and 91% representing a variation in internal dissipation of 86mW to 490mW! This is just because of a $\pm 2\%$ current measurement error, which is not uncommon.

OUTPUT OVERLOAD/SHORT CIRCUIT CHARACTERISTICS

Overload is when output current exceeds the converter rating. For a slight overload, a converter may continue to operate with higher temperature rise and with degraded regulation and noise specifications. For higher overloads, it may limit its output current and drop the output voltage or even shutdown and try to regularly restart. The simplest converters may be damaged by a sustained overload while others may protect themselves with a thermal shutdown for example. The performance of a particular converter is summarised by a graph of output voltage against load current as shown in Figure 26. This can be generated by varying the load with a simple resistor or an electronic load in 'constant resistance' mode. Note that in some cases there are two stable voltage points for a particular current such as A and B for a 'foldback' protection characteristic.

Highly capacitive loads can be seen as a short term overload and cause a converter to delay starting, not start at all or 'latch' into point B in Figure 26. Maximum capacitance from the datasheet should be observed to avoid such problems.

'Short circuit' needs careful definition. A 'short' always has some real but small resistance and its effect on a converter can be very different between being applied at the converter terminals and at a connected load at the end of the wiring or tracking. In the latter case, the converter sees a low resistance rather than a true short and may enter a current limit mode rather than shutdown. As a converter supplier cannot know the detail of external connections. Depending on the converter type, with a short circuit, the converter may current limit, latch off, switch off and try to restart or enter a high frequency oscillation mode effectively limiting power output. For Murata Power Solutions, where a converter is specified as 'short circuit proof' this applies under all conditions of temperature and initial loading.

Figure 26: OUTPUT CURRENT LIMITING CHARACTERISTICS

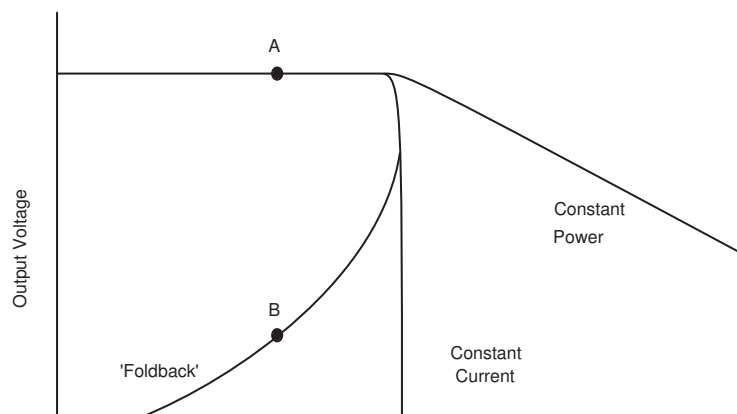

15. DERATING GUIDELINES

DC-DC converters have an operating temperature range over which they can supply power. Maximum power may not be available at high temperatures due to internal thermal limits so 'derating' curves are sometimes given showing how much power can be taken.

Unless otherwise stated, the curves given relate to operation in free air with only natural convection cooling. If forced air is available, depending on airspeed, the derating curve is modified. See Figure 27 as an example. Here maximum power is available up to 70°C, perhaps limited by current ratings of internal components. After 70°C, internal components have been measured to come within a set margin of their maximum temperature ratings so power must be reduced as temperature rises to keep this margin. At 105°C, no further power output is allowed, typically because a component evaluated for safety such as the internal PCB has reached a maximum allowed temperature within a set margin.

Murata's derating curves are given for the worst case converter input voltage. If the input range is restricted, there may be improvement in the derating performance with load and temperature. Contact Murata for more details.

In real applications, unobstructed convection cooling is not always available and in fact other components around the DC-DC converter may block airflow or even heat up the DC-DC converter from their own dissipation. Datasheets for DC-DC converters may therefore often quote a maximum allowable case temperature rise above ambient measured at a specified point due to internal and external heating effects. This ensures that the converter is operating within its allowable derating curve.

DC-DC converters may be operated outside of their derating curves for short periods. The period allowed depends closely on the thermal mass of the converter and the duty cycle or repetition rate of the excess power or temperature. Contact Murata for advice.

As stated, all Murata DC-DC converters have margins of safety for the internal component operating temperatures. However, it is recommended that a converter be derated further in the application to perhaps 75% normal loading for best reliability and life time. The consequent reduction in converter case and component temperatures will have a substantial effect on the MTTF figure, which typically doubles for each 10° reduction in component temperature.

Figure 27: TYPICAL DERATING CURVE

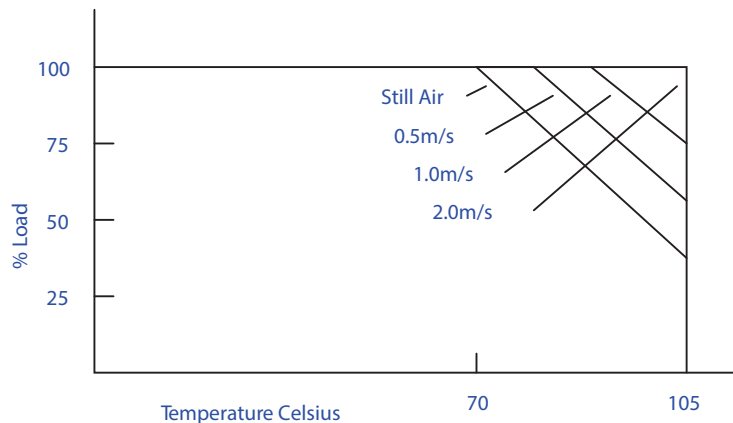

16. BOARD LAYOUT FOR DC-DC CONVERTERS

DC-DC converters should be mounted with adequate clearance around them to allow convection cooling and avoid heat build-up. The clearance depends on the application and should be verified by the user. Note that the simplest of unregulated DC-DC converters dissipate appreciable power even with no load.

PCB tracks to the converter should be thick enough for the associated current and ideally power and return tracks should run closely together on the input and output for minimum EMI emission and pick-up. See Figure 28.

Input and output capacitors if fitted should be located close to the converter and the tracks should run through the capacitor terminal connections as shown in Figure 28.

If the converter inputs or outputs are paralleled, the tracking should be symmetrical for best sharing and minimum interaction. See section 'CONNECTING DC-DC CONVERTER INPUTS AND OUTPUTS IN PARALLEL'.

Generally, running unrelated tracks under a DC-DC converter should be avoided. EMI pick-up may occur as some DC-DC converters can generate an external local magnetic field.

The space between DC-DC converter input and output pins is part of the isolation barrier. External tracks should therefore not reduce this distance below the application requirement. Where a converter holds a safety agency approval, the space between input and output pins is often the minimum required by the agency so no tracks are allowed in between.

There may however be advantage in running a ground plane under the DC-DC converter if it does not compromise the isolation barrier. This can help with EMI issues. Some DC-DC converters have metal cases. Care should be taken to ensure that the edges of the metal do not contact tracks on the PCB. Often the metal case will be connected to the return output pin.

Often DC-DC converter pins are marked as 'no connection'. This means no external connection is allowed as the pin may be internally connected to a circuit node. No external track should therefore connect to or run through those pins.

If a DC-DC converter function is not used such as a shutdown pin, it is good practice to tie it to ground or a voltage that sets it in the 'disabled' state to avoid the possibility of noise pick-up on the pin, usually via a low value resistor.

Figure 28: DC-DC LAYOUT

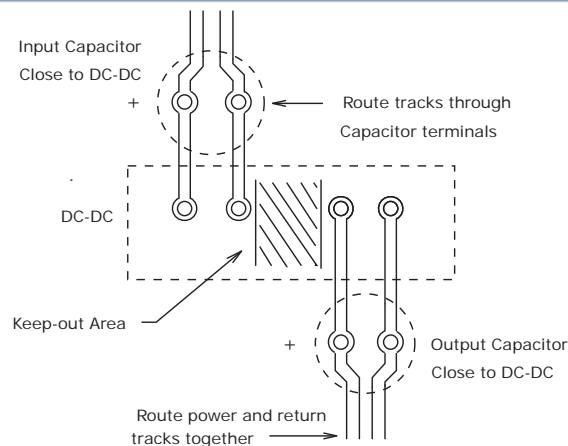

17. APPLICATIONS

AUXILIARY POWER RAIL GENERATION

A DC-DC converter can be used to locally generate extra voltage rails such as $\pm 15V$ from a system 12V or perhaps 5V from 3.3V as shown in Figure 4. Isolation may not be necessary in these circumstances. However, an isolated converter can be an easy way to generate another rail simply by the connection arrangement. Figure 5 shows various arrangements of connections that can generate higher voltages or negative voltages at low power. This may be far more cost effective than specifying a system supply with these rails as auxiliary outputs.

CONNECTING DC-DC CONVERTER OUTPUTS IN SERIES

Generally it is possible to connect low power isolated DC-DC converter outputs in series to achieve higher voltages or positive and negative rails. However, depending on the converter type, there is the possibility of one of the converters seeing a reverse voltage on its output at power up if the other DC-DC starts up first. This can be damaging or at least cause anomalous behavior. For this reason it is recommended that parallel diodes, ideally Schottky type, be connected across each converter output to prevent reverse biasing as shown in Figure 22. If the DC-DC converters have a connection between input and output ground, there are also other possible problems where 'sneak' system currents can flow through the converter outputs before switch on causing anomalous behavior. Again parallel output diodes solve the problem. See Figure 22.

CONNECTING DC-DC CONVERTER INPUT AND OUTPUTS IN PARALLEL

It is not recommended that outputs of low power isolated regulated converters are paralleled to produce high power as the parts will not share the current. If unregulated or regulated parts are paralleled for redundancy, that is, the total load never exceeds the capability of one converter, series isolating diodes should be fitted in each output so that failure of one converter does not affect the other. To get the benefit of redundancy, each DC-DC converter should be monitored before the gating diode to indicate if it has failed.

It is quite normal to parallel inputs of DC-DC converters of multiple types in one system. However it is recommended that an LC filter be fitted in the power line of each converter as shown in Figure 22. This is to prevent noise from one converter affecting the others. Noise coupling can cause chaotic switching behavior and at worst converter failure.

'HIGH-SIDE' GATE DRIVE POWER

Some isolated low power DC-DC converters from Murata, the MGJ series, are designed specifically for powering MOSFET or IGBT gate drive circuits that operate with a local reference which is at a high voltage and switched at a high frequency – so called 'high-side' circuits. See Figure 29. In these applications the DC-DC converter sees across its barrier a waveform switching between a high voltage and ground at frequencies up to hundreds of kHz with extremely fast edges. Examples would be IGBT circuits switching 3kV at 20kHz with edge rates (dV/dt) of 30kV/us or SiC MOSFET circuits switching 1200V at 200kHz and 80kV/us dV/dt. The datasheets for the MGJ series include specific application notes for their use (Figure 30).

In these applications, careful attention must be given to any safety rating required. Although the MGJ series parts have been tested for reliable operation with several kilovolts switched across their barriers, if they are also used as a safety barrier, the voltage allowed is much less according to safety agency regulations. When used above the agency rated voltage, the DC-DC converter barrier must be regarded as having only BASIC or FUNCTIONAL rating only depending on actual applied voltage. See the datasheets for more detail.

ISOLATED INTERFACE POWER

A very common application for low power isolated DC-DC converters is to provide isolated power rails for the isolated side of a data interface. Isolation in data interfaces is used to prevent ground currents between separated equipment and to provide some immunity to common mode transients and noise external to equipment, including lightning strikes. Most common interface standards used in industry are RS485, RS422, RS232 and 4/20mA current loop. CANBUS and USB are also common in industrial and medical applications. Typical application circuits are given in Figures 1 to 3 using Murata DC-DCs to provide isolated power.

17. SOLDERING INFORMATION

WAVE SOLDERING

Murata recommends that wave solder profiles for our through products should not exceed IEC 61760-1 Section 6.1.3. Please refer to Figure 31.

Figure 29: DC-DC PROVIDING ISOLATED 'HIGH-SIDE' GATE DRIVE POWER

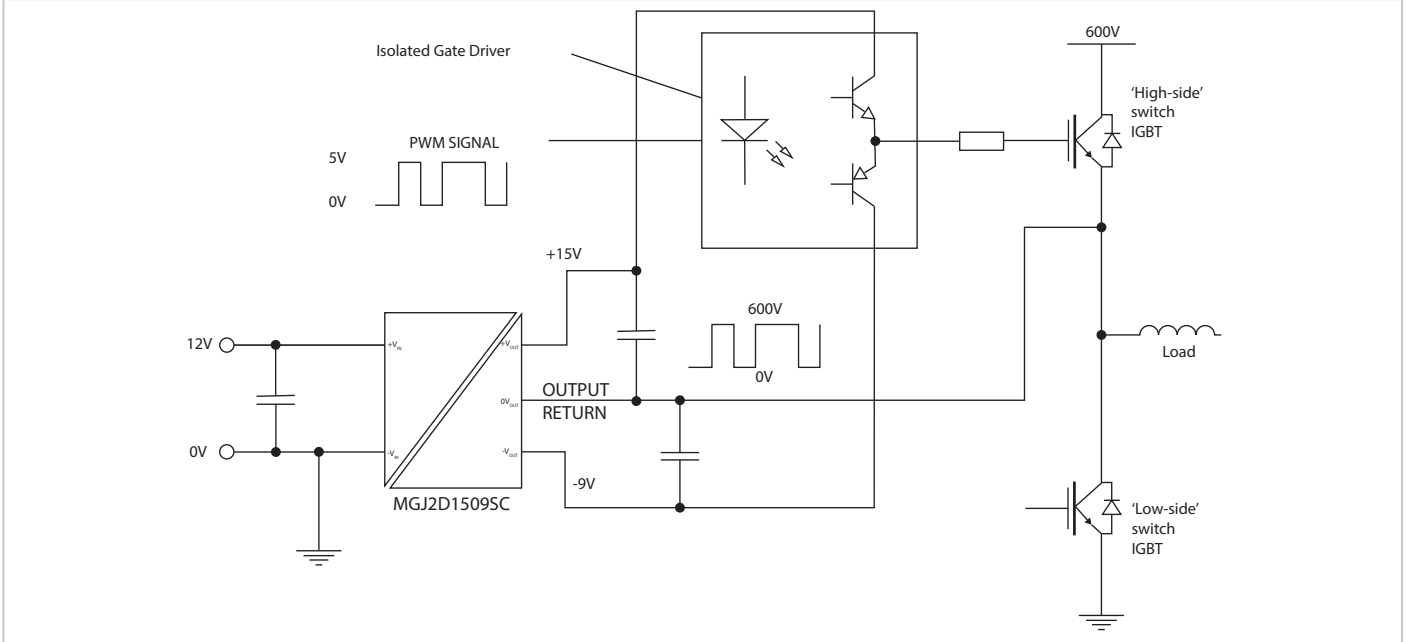

Figure 30: ISOLATED GATE DRIVE FOR SIC MOSFET

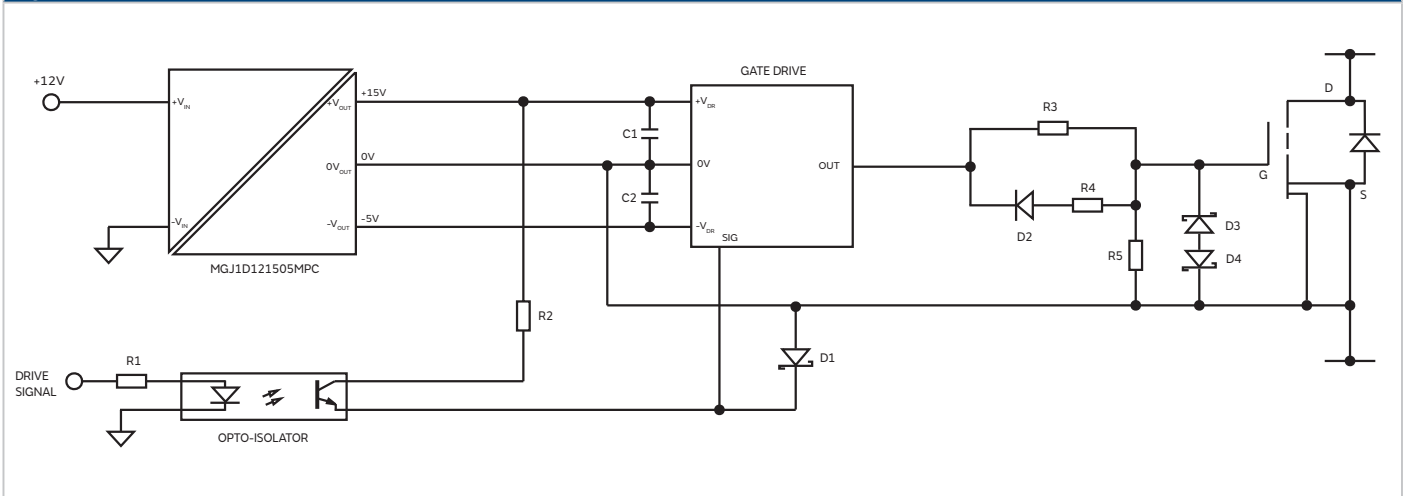
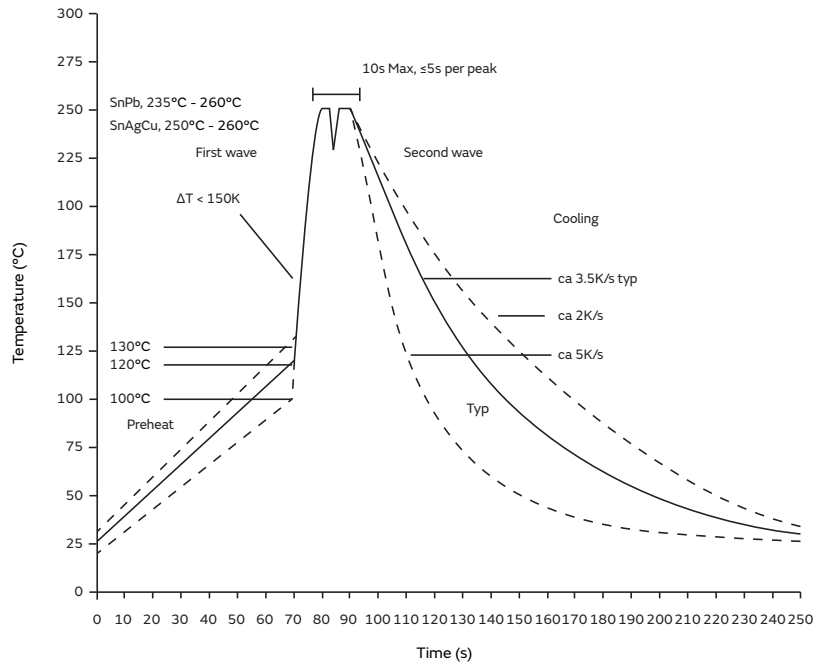

Figure 31: WAVE SOLDER PROFILE



All products are subject to the following [operating requirements](#) and the [Life and Safety Critical Application Sales Policy](#):
 Refer to: <http://www.murata-ps.com/requirements/>

Murata Power Solutions (Milton Keynes) Ltd. makes no representation that the use of its products in the circuits described herein, or the use of other technical information contained herein, will not infringe upon existing or future patent rights. The descriptions contained herein do not imply the granting of licenses to make, use, or sell equipment constructed in accordance therewith. Specifications are subject to change without notice.
 © 2025 Murata Power Solutions (Milton Keynes) Ltd.