

User Guide  
MP-QW80EVAL-01  
Analog DC-DC  
Evaluation Board

## Table of Contents

<b>1. Introduction</b> .....	3
<b>2. Setup</b> .....	4
<b>2.1 Connections</b> .....	4
<b>2.2 On Board Component Values</b> .....	5
<b>2.2.3 Under Voltage Lockout (UVLO)</b> .....	5
<b>2.2.4 Output Voltage Trim Resistors</b> .....	5
<b>2.2.5 Sense Connections</b> .....	5
<b>2.2.6 Hold Up Circuit</b> .....	6
<b>2.2.7 External Fusing</b> .....	6
<b>2.2.8 On/Off Control</b> .....	6
<b>3. EMI Circuit</b> .....	7
<b>4. Circuit Schematic</b> .....	9
<b>5. Mechanical Drawings / Dimensions</b> .....	10
<b>6. Packaging Information</b> .....	11
<b>Figure 1 PCB</b> .....	3
<b>Figure 2 Connectors Position / Resistor Functions</b> .....	4
<b>Figure 3 UVLO Resistor Value Table</b> .....	5
<b>Figure 4 Output Trim Resistor Values</b> .....	5
<b>Figure 5 Remote Sense Connection</b> .....	5
<b>Figure 6 Hold Up Capacitor Values</b> .....	7
<b>Figure 7 EMI Schematic</b> .....	7
<b>Figure 8 EMI BOM</b> .....	7
<b>Figure 9 EMI Results</b> .....	8

## 1. Introduction

### MP-QW80EVAL-01 Evaluation Board User Guide

The MP-QW80EVAL-01 Evaluation Board is designed to assist with the evaluation of the IRQ-W80, 150W, 10:1 input range DC/DC converter module from Murata Power Solutions. The IRQ-W80 series of isolated regulated converter modules, deliver an impressive 150W single output from a wide input range of 16V – 160Vdc, complying with the input battery voltage transient range of EN50155.

The quarter brick module offers high efficiency levels up to 89%, with an input – output isolation voltage of 4242Vdc. The module features Overvoltage, Overcurrent, Short Circuit, Adjustable output voltage, Adjustable Current Limit, Positive or Negative Logic enable and Hold up function for an external capacitor. See Page 9 for full schematic.

**Figure 1 – Evaluation Board**

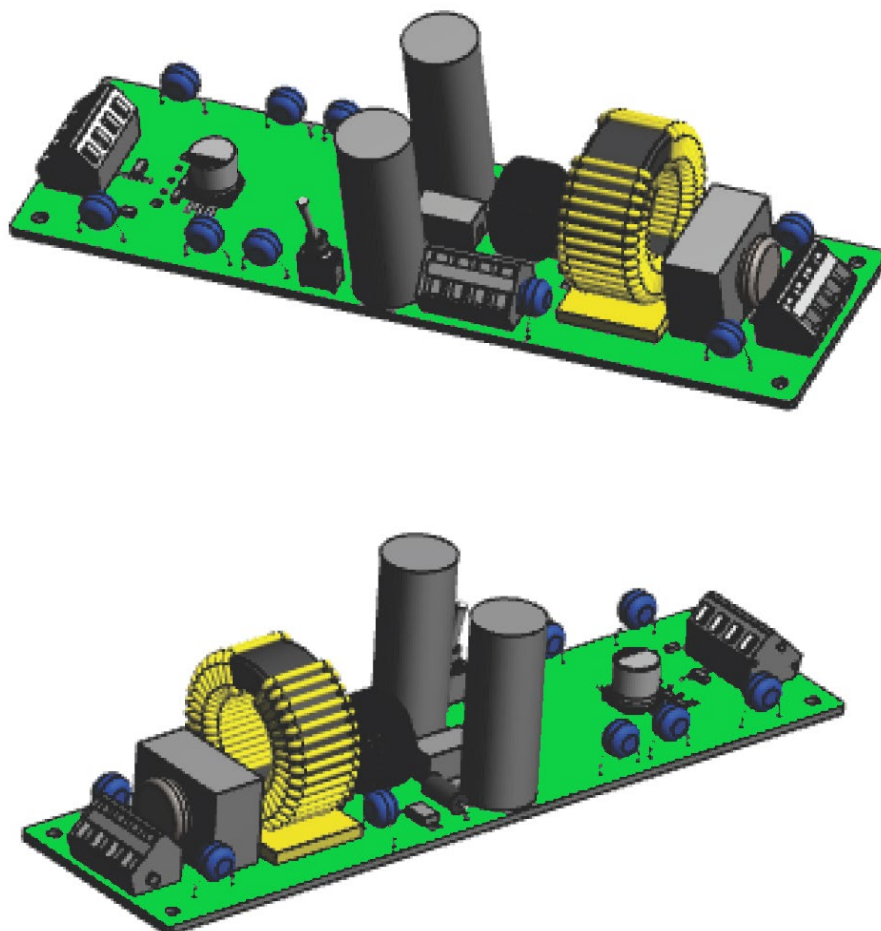

## 2. Setup

### 2.1 Connections

This section describes the connector locations/pinouts on the evaluation board, to enable correct set up.

Figure 2 - Connectors Position / Resistor Functions (Top View)

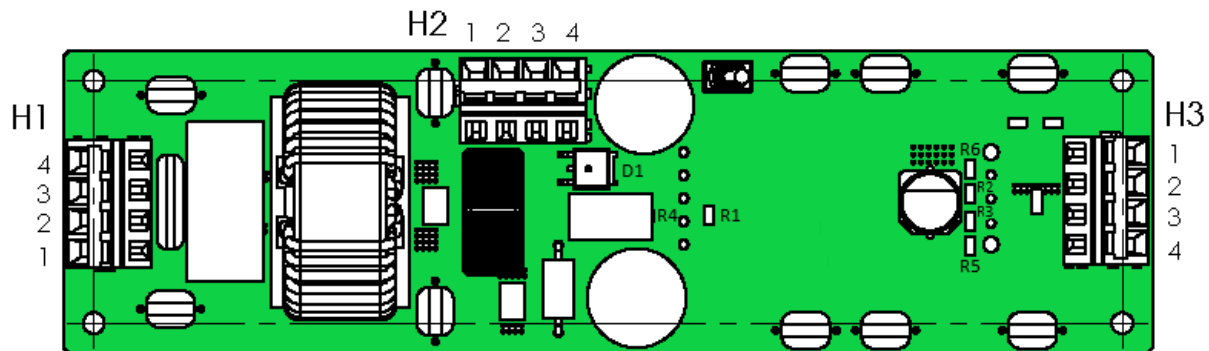

H1 Input Voltage Connector	
Pin 1	VIN-
Pin 2	VIN-
Pin 3	VIN+
Pin 4	VIN+

H2 Signal Connector	
Pin 1	CHOLD+
Pin 2	VIN-
Pin 3	ON/OFF
Pin 4	PE

H3 Output Voltage Connector	
Pin 1	VOUT-
Pin 2	VOUT-
Pin 3	VOUT+
Pin 4	VOUT+

Resistor / Function	
R1	UVLO
R2	TRIM DOWN
R3	TRIM UP
R4	CHARGE
R5	SENSE (+)
R6	SENSE (-)

R1, R2, R3, R5, R6 = SMD0805

## 2.2 On Board Component Values

### 2.2.3 Under Voltage Lockout. (UVLO)

By adding a resistor to R1 position as per the table below, the converter will shut down if the input voltage drops below the threshold. The converter will automatically restart when the input voltages rises above the UVLO threshold. Leave unconnected if not used.

**Figure 3 - UVLO Resistor Value Table**

V <sub>in</sub>	24V	36V	48V	72V	96V	110V
Turn Off	12±1V	20.5±1V	29±1V	43±1.5V	60.5±2V	64.3±2V
Turn On	15±1V	23.5±1V	32±1V	46±1.5V	63.8±2V	67.3±2V
Resistor Value	Open	20.5kΩ	10.7kΩ	5.9kΩ	3.74kΩ	3.48kΩ

### 2.2.4 Output Voltage Trim Resistors

R2, R3 – Trimming the Output Voltage.

The trim pin of the converter allows the user to adjust the output either +10% or -10% by using fixed value resistors.

**Figure 4 - Output Trim Resistor Values**

12V Output				
Output Voltage	10.8V	11.4V	12.6V	13.2V
R3 + Trim	NA	NA	390.89kΩ	204.27kΩ
R2 - Trim	8kΩ	18kΩ	NA	NA

### 2.2.5 Sense Connections

If intended to utilize the output sense feature, please ensure that you short out, or add a zero ohm link in positions R5, R6. If it is proposed to use the sense function, then please leave R5, R6 open circuit, and connect output sense lines to the load. The sense connections can compensate up to 0.5V voltage drop of output leads.

**Figure 5 - Remote Sense Connection**

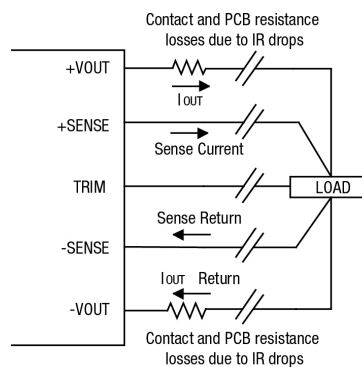

### 2.2.6 Hold Up Circuit

The BUS pin of the IRQ150W80 module, is a voltage source output of 80Vdc to allow external capacitors to be connected in order to provide hold up power of the converter. The eval board houses a resistor (R4) to slowly charge the capacitors up, and a feed forward diode (D1) for rapid discharge into the module during hold up mode. The capacitor value can be as per the below table to provide 10msec or 20msec of hold up. Connect the capacitor to H2, Pin 1 = +CHOLD, Pin 2 = VIN-, as per Figure 2.

**Figure 6 - Hold-Up Capacitor Values**

Hold-up time	24Vin	36Vin	48Vin	72Vin	96Vin	110Vin
10ms	1800uF	1800uF	1800uF	1800uF	550uF	330uF
20ms	3600uF	3600uF	3600uF	3600uF	1100uF	660uF

### 2.2.7 External Fusing

The evaluation board does not have any fusing protection, the user must provide external fusing, circuit breaker protection as required.

### 2.2.8 On/Off Control

Connect the On/Off pin (Pin 3, H2) to VIN- (Pin 2, H2) connection if “Negative” logic level is used in the part number of the IRQ-W80. Leave the On/Off pin open if “Positive” logic level is used.

Note: A mechanical On/Off switch is also provided on the top side of the evaluation board.

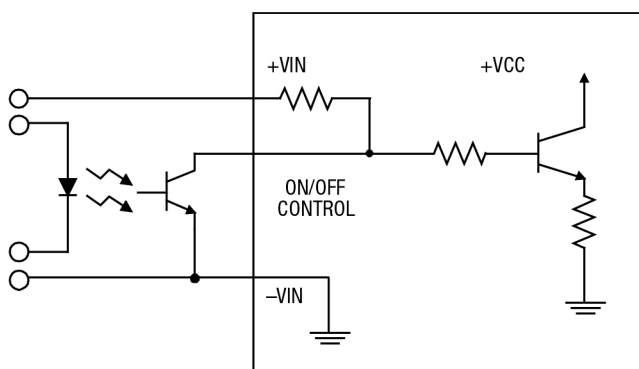

### 3. EMI Circuit

The following schematic below meets EN55011 Class A.

**Figure 7 - EMI Schematic**

**Figure 8 - EMI BOM**

Part	Manufacturer	MPN	Description
MOV	Epcos	B72214S0141K101	Varistor, 180V
C1	Faratronic	C212E475K9AC000	4.7uF, 250V
C2, C3, C4	Murata	GRM43DR72E474KW01L	0.47uF, 250V
C5, C6, C11, C12, C13, C14	Murata	DE1E3RA102MA4BQ01F	1000pF, 300VAC
C15, C16	Murata	DE1E3RA472MA4BQ01F	4700pF, 250V
L1	Würth	7448262013	2x1.3mH CMC
L2	Bourns	2101-V-RC	10uH
C9, C10	United Chemicon	EKXJ251EXX271ML40S	270uF, 250V low ESR

**Figure 3 - EMI Results**

Limit Line as per EN55011 level A

**Vin = 48V, Line L**

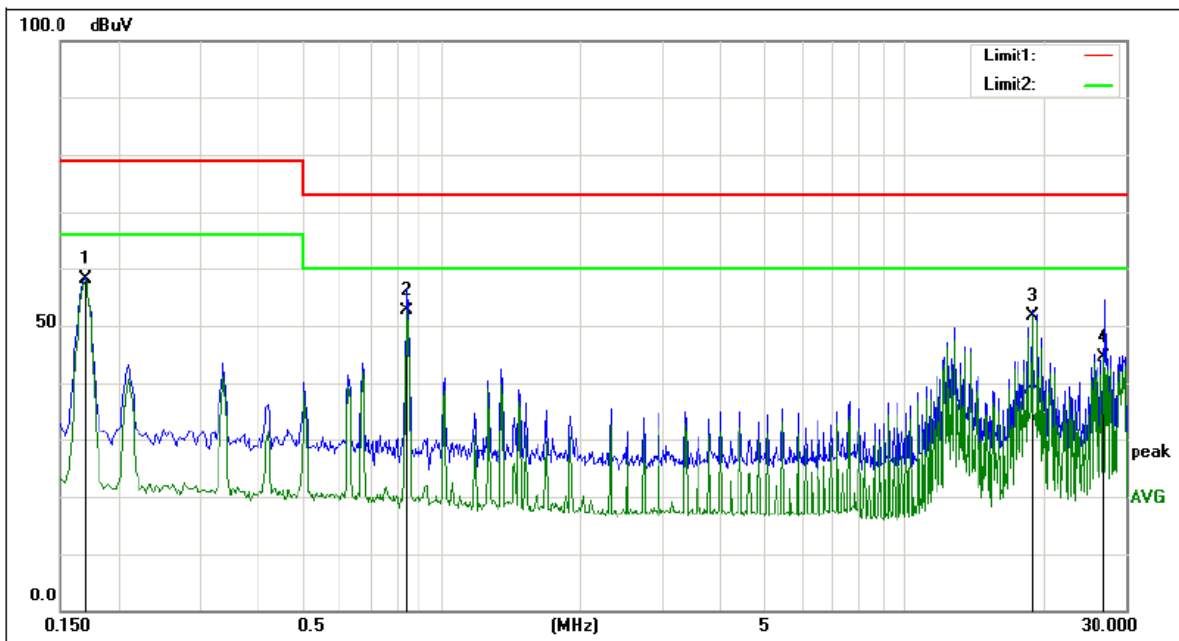

No.	Frequency (MHz)	Reading (dBuV)	Correct Factor(dB)	Result (dBuV)	Limit (dBuV)	Margin (dB)	Remark
1	0.1700	38.58	19.55	58.13	66.00	-7.87	AVG
2	0.8420	33.04	19.63	52.67	60.00	-7.33	AVG
3	18.9140	31.58	19.94	51.52	60.00	-8.48	AVG
4	26.8980	24.51	19.96	44.47	60.00	-15.53	AVG

## 4. Circuit Schematic

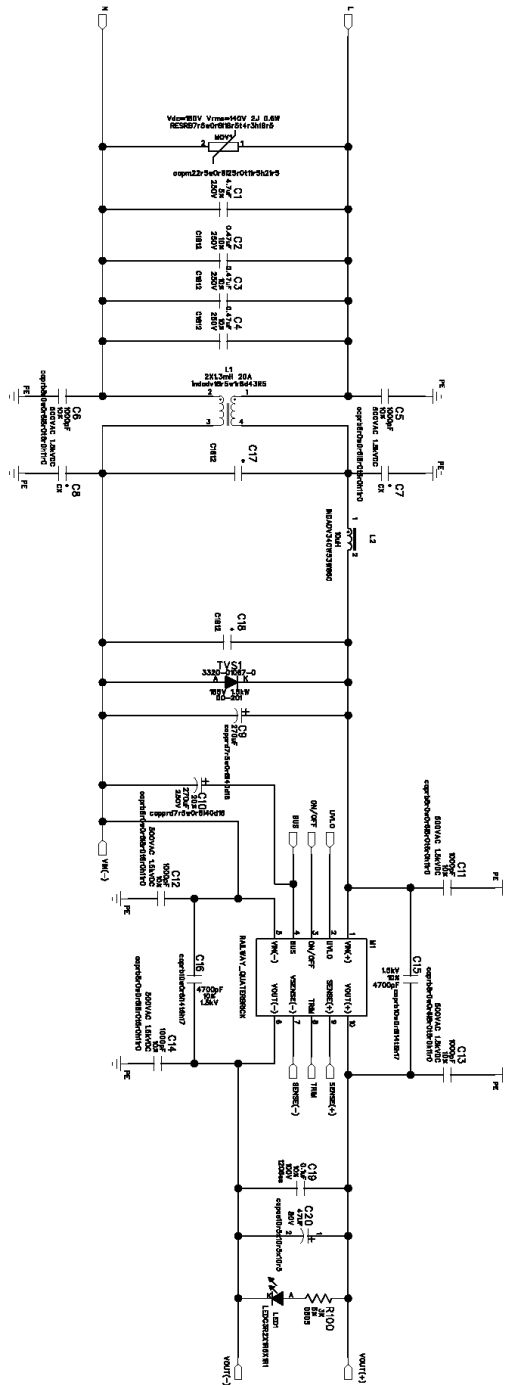
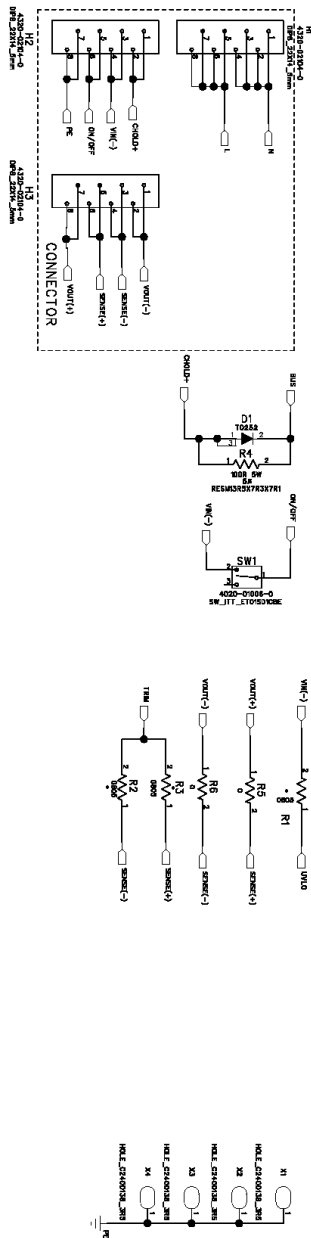

## 5. Mechanical Drawings / Dimensions

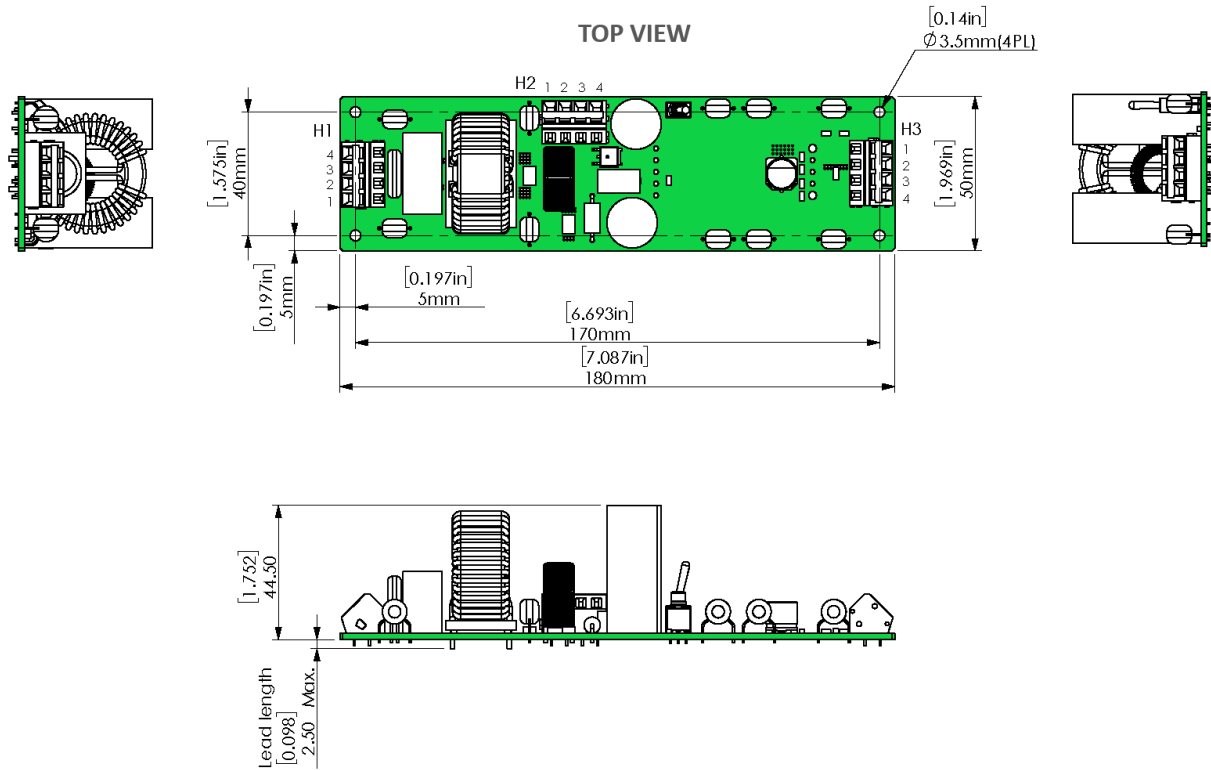

Connector	Pin number	Function
H1	1	VIN-
	2	
	3	VIN+
	4	
H2	1	CHOLD+
	2	VIN-
	3	ON/OFF
	4	PE
H3	1	VOUT-
	2	
	3	VOUT+
	4	

NOTES:  
 UNLESS OTHERWISE SPECIFIED:  
 1: ALL DIMENSIONS ARE IN INCHES [MILLIMETER].  
 2: ALL TOLERANCES:  
     x.xx in, ±0.02 in (x.x mm, ±0.5 mm),  
     x.xxx in, ±0.01 in (x.xx mm, ±0.25 mm).  
 3: UNIT WEIGHT = 560 grams

## 6. Packaging Information

Item No.	Part Number	Description	Qty
1	2300214	Carton, 10"x 10"x4.45"	1
2	2300216	Pad, ESD Foam, 9.92" SQ, 1/4" Thk	1 (NOTE 8)
3	6256-01640-0	PACKING FOAM	2
4	2300159	Label, Paper, 1.0" x 1.5"	1
5	5600-01098-0	Label, ESD Warning	1
6	5652-01166-0	Label, Paper, Shipping 2" x 4"	1 (NOTE 6)
7	6200-01211-0	ESD Tape, 3/4" Wide	.33'

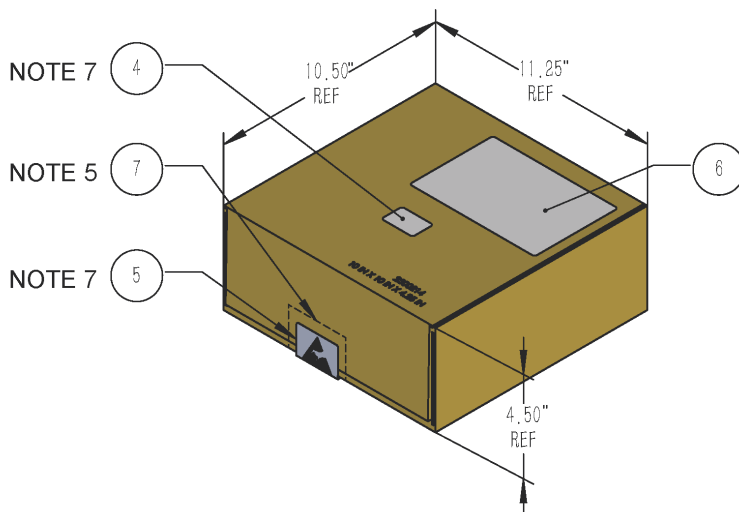
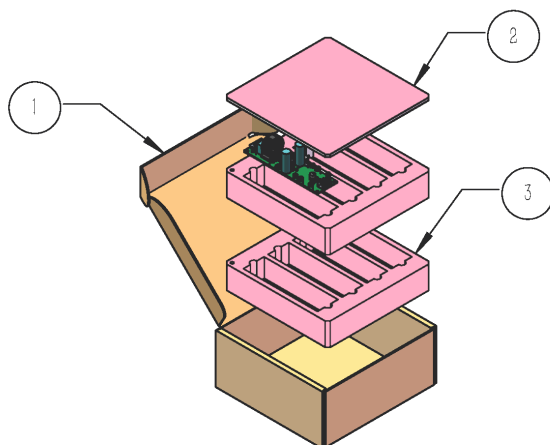

**NOTES:**

- THIS DOCUMENT DEFINES THE GENERAL PACKING RULES FOR THE APPLICABLE SHIPPING KIT. INFORMATION FOR SEALING AND MARKING IS NOT PART OF THIS DOCUMENT.
- REFER TO SHIPPING KIT BOM DETAILS.
- INSERT UNITS INTO FOAM POCKETS UB TRAYS APPROX AS SHOWN.
- EACH FOAM TRAY (6256-01639-0) CONTAINS 4 UNITS. IN FULL MPQ QUANTITIES, 2 TRAYS EQUAL TO A TOTAL OF 8 (2x4) UNITS PER BOX.
- FRONT FLAP SHALL BE SEALED WITH ESD TAPE SPECIFIED OR EQUIVALENT AFTER THE BOX IS CLOSED.
- LABEL (ITEM 6) USED FOR MFR OVERPACK CARTON.
- APPLY ESD LABEL (ITEM 5) OVER TAPE USED TO SEAL BOX AND APPLY IDENTIFICATION LABEL (ITEM 4) APPROX AS SHOWN.
- PAD (ITEM 2) MAY, AT MFR'S OPTION, BE EXCHANGED FOR THINNER PAD IF FOAM STACKUP EXCEEDS CARTON HEIGHT BY >1/8" OR ADDITIONAL PAD MAY BE ADDED IF STACKUP IS BELOW INSIDE CARTON HEIGHT BY > 1/8" ALTERNATE PADS: 1/4" THK=2300216, 3/8" THK=2300218, 1/2" THK=2300219, 3/4" THK=2300221.

Murata Power Solutions, Inc.  
 129 Flanders Rd., Westborough, MA 01581 USA  
 ISO 9001 and 14001 REGISTERED



**This product is subject to the following [operating requirements](#) and the [Life and Safety Critical Application Sales Policy](#):**

Refer to: <http://www.murata-ps.com/requirements/>

Murata Power Solutions, Inc. makes no representation that the use of its products in the circuits described herein, or the use of other technical information contained herein, will not infringe upon existing or future patent rights. The descriptions contained herein do not imply the granting of licenses to make, use, or sell equipment constructed in accordance therewith. Specifications are subject to change without notice.

© 2021 Murata Power Solutions, Inc.