

Meeting EMI Requirements for Rolling Stock & Railway Applications

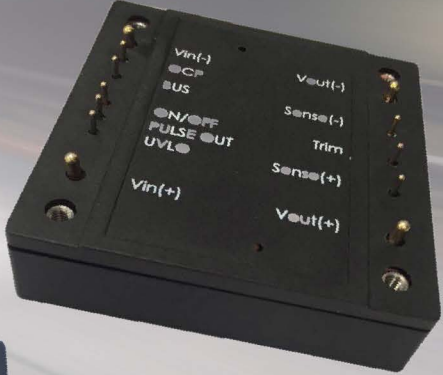

CONTENTS

1	INTRODUCTION	2
2	RAILWAY STANDARDS	3
3	PERFORMANCE CRITERIA	3
4	VOLTAGE TRANSIENTS	4
5	INTERRUPTIONS OF VOLTAGE SUPPLY	5
6	APPLICATIONS	6
7	TYPES OF DC/DC CONVERTERS	7
8	EMISSIONS LIMIT LEVELS	8
9	IMMUNITY LIMIT LEVELS	8
10	FILTER DESIGN	9
10.1	INPUT CURRENT	9
10.2	IMMUNITY	10
10.3	COMMON/DIFFERENTIAL MODE FILTERING	11
10.4	IMPEDANCE	12
10.5	FREQUENCY CUT OFF	13
10.6	Q DAMPING FACTOR	14
11	DIFFERENTIAL MODE FILTER DESIGN	15
11.1	DIFFERENTIAL MODE FILTERING	15
11.1.2	IMPEDANCE CALCULATION	15
11.1.3	GAIN CALCULATION	15
11.1.4	FREQUENCY CUT OFF CALCULATION	15
11.1.5	L & C CALCULATION USING IMPEDANCE PAPER	16
11.1.6	DAMPING RESISTOR CALCULATION	17
11.1.7	DIFFERENTIAL FILTER	17
12	COMMON MODE FILTER DESIGN	18
12.1.1	CM CHOKE DESIGN	18
12.1.2	Y CAPACITORS	18
12.1.3	X CAPACITOR	18
13	CONCLUSION	19
14	APPENDICES	20
15	REFERENCES	21

FIGURES

1	RAILWAY STANDARDS	3
2	PERFORMANCE CRITERIA. (1)	3
3	TYPICAL POWER TRAIN BLOCK DIAGRAM. (2)	4
4	BATTERY BUS VOLTAGE TRANSIENT RANGE	4
5	INTERRUPTION VOLTAGE SUPPLY CLASSES	5
6	INTERRUPTION VOLTAGE	5
7	TYPICAL ROLLING STOCK APPLICATIONS	6
8	TYPICAL ROLLING STOCK APPLICATIONS	6
9	EMBEDDED STYLE DC/DC CONVERTER	7
10	CHASSIS MOUNT STYLE SOLUTION	7
11	IMMUNITY SCHEMATIC	10
12	COMMON MODE NOISE	11
13	DIFFERENTIAL MODE NOISE	11
14	IMPEDANCE PAPER	16
15	DIFFERENTIAL FILTER SCHEMATIC	17
16	COMMON MODE FILTER SCHEMATIC	18

EQUATIONS

1	INPUT CURRENT	9
2	INPUT IMPEDANCE	12
3	OUTPUT IMPEDANCE	12
4	FREQUENCY CUT OFF	13
5	GAIN	13
6	Q FACTOR	14
7	FREQUENCY CUT OFF / GAIN	15
8	FREQUENCY CUT OFF CM	18

John Quinlan BSc, MIET

INTRODUCTION.

This paper introduces the EMI specifications applicable to the standards for rail applications, and guides through a simple filter design to meet the standards.

All electrical equipment installed onto rolling stock (railway) applications must be approved to BS EN50155:2017. This standard defines the electrical and environmental operating conditions electrical equipment must meet. The standard is a detailed design guideline that the supplier of “end use equipment” used on rolling stock applications must be designed and qualified to.

Within the scope of EN50155 there are many different test parameters that must be designed for and tested to including:

- Environmental – Temperature, humidity, altitude, shock/vibration, pollutants.
- Electrical – EMC, DC voltage variations, transients/immunity, insulation.
- For each of the above test methods, a subset of standards is also called up such as:
 - EN45545 – Fire protection on railway vehicles.
 - EN60068 – Environmental testing.
 - EN61373 – Shock & Vibration.
 - Etc.

The standard also calls up design guidelines for equipment including- wiring practices, construction, layout guidelines, PCB assembly etc.

For the purpose of this paper, we will only focus on the EMI section.

There are also other railway specific applications i.e. “trackside” these tend to be static applications for signalling, monitoring and control. These are covered also by EN50155 but call up a different set of sub standards.

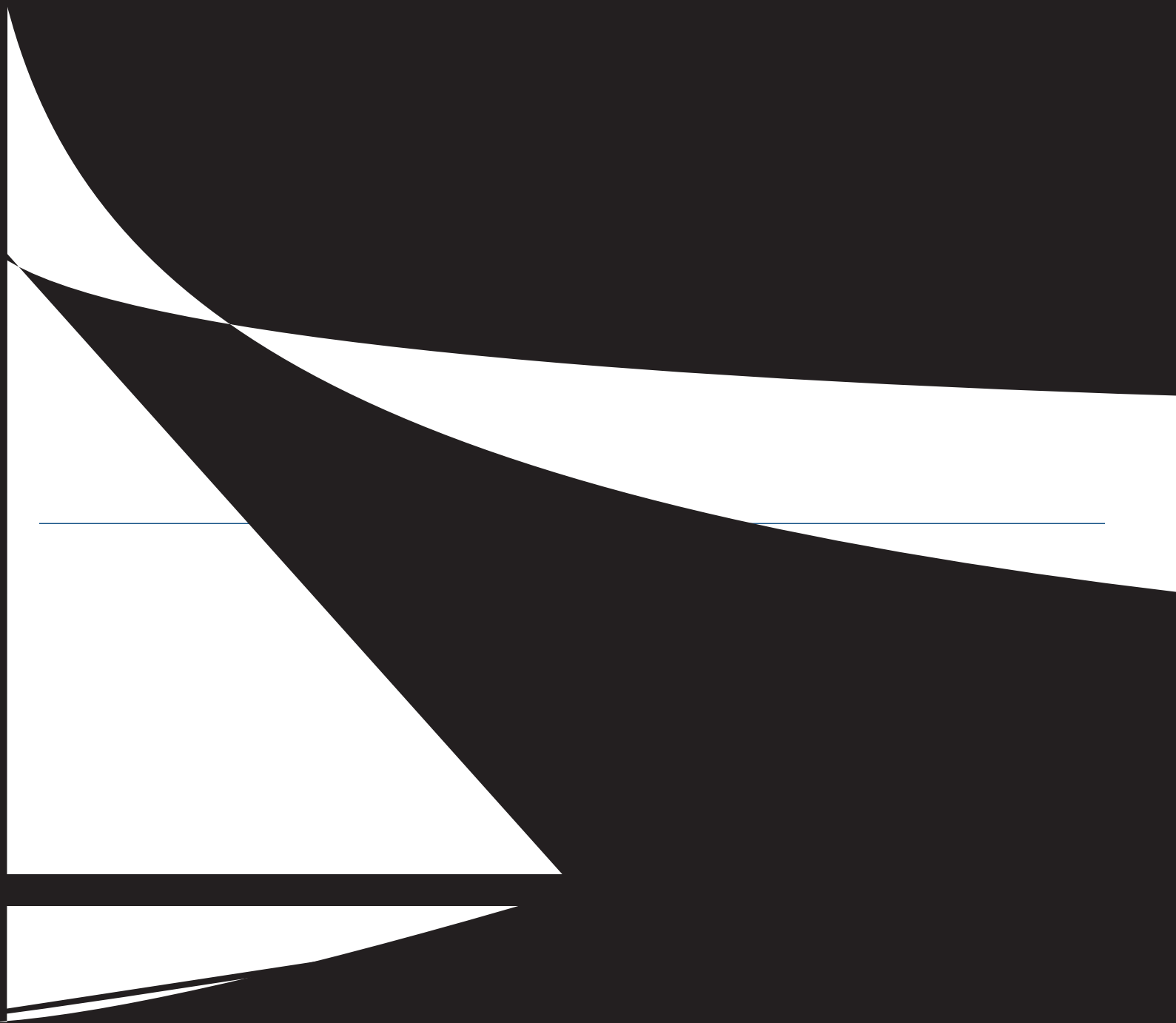

4 VOLTAGE TRANSIENTS

Another important technical requirement for equipment used on rolling stock is the DC supply transient range conditions, as per BS EN50155:2017. All electrical equipment used on rolling stock is powered via the onboard battery and auxiliary converter system (Fig 3). Depending on the train manufacturer and geographical region – determines the on-board battery voltage range.

The variants of battery voltages used on rolling stock are shown in Fig 4. The nominal battery voltage has a variant input voltage range, due to charging and discharging of the battery. There is also a transient range specified which is a result of load dump, load source and starting of the engine in emergency situations on the bus voltage.

All equipment installed on rolling stock must meet these input voltage ranges.

FIGURE 3 Typical power train block diagram (2)

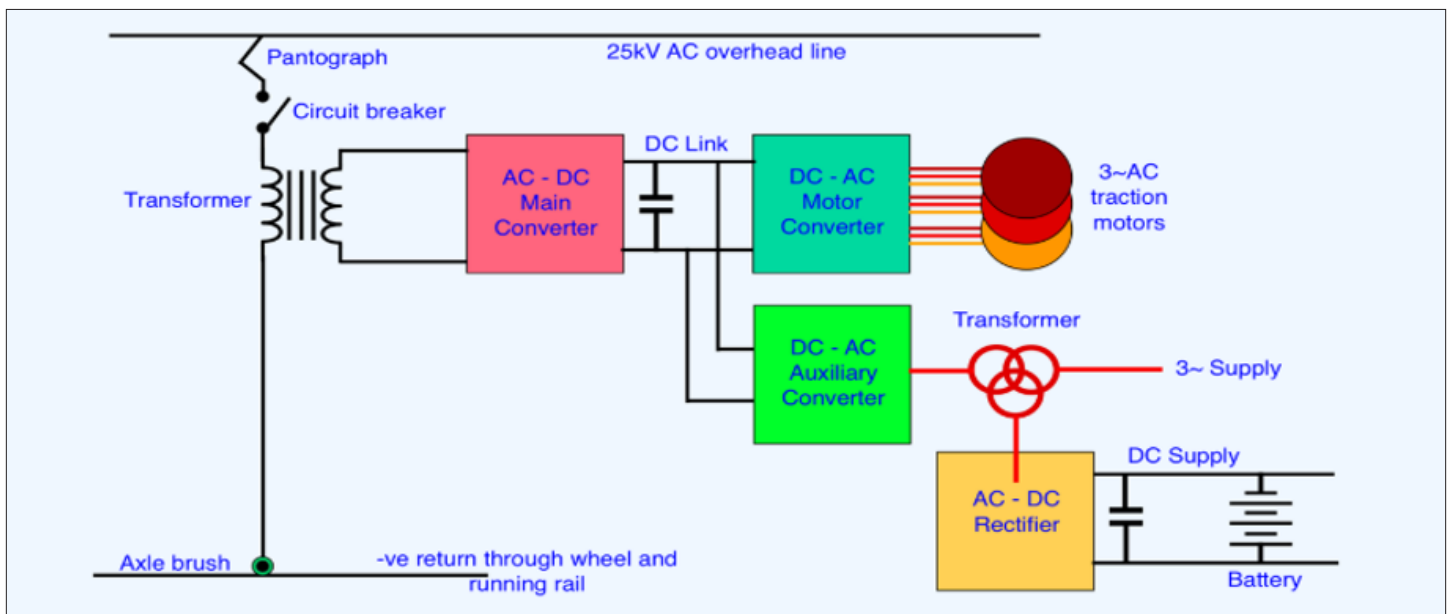

FIGURE 4 Battery Bus Voltage transient range

EN50155 (2017) STANDARD			
Nominal Input	Permanent Input Range (0.7 - 1.25 Vin)	Brownout 100ms (0.6 x Vin)	Transient 1s (1.4 x Vin)
24V	16.8V – 30V	14.4V	33.6V
28v	19.6V – 35V	16.8v	39.2V
36v	25.2v - 45v	21.6v	50.4v
48V	33.6V – 60V	28.8V	67.2V
72V	50.4V – 90V	43.2V	100.8V
96V	67.2V – 120V	57.6V	134.4V
110V	77V – 137.5V	66V	154V

5 INTERRUPTIONS OF VOLTAGE SUPPLY

Another key parameter to consider regarding the DC supply voltage on rolling stock, is the temporary interruption of the supply voltage (Fig 5.) as per BS EN51055:2017, this can be a result of a short circuit/overload on the line which needs resetting, or the cranking of a combustion engine if diesel locomotive is used. There are 3 classes of interruptions defined, depending on the application and its intended use. For class S2, S3 requirements, additional hold up capacitance is required on the DC supply voltage supplying the equipment.

FIGURE 5 Interruption Voltage Supply Classes

Class	Requirements
S1	In case of voltage interruption, no performance criterion is requested but the equipment shall continue to operate as specified after the voltage interruption.
S2	In case of voltage interruption up to 10msec the equipment shall behave according to Performance criteria A.
S3	In case of voltage interruption up to 20 mSec the equipment shall behave according to performance criterion A.

FIGURE 6 Interruption Voltage

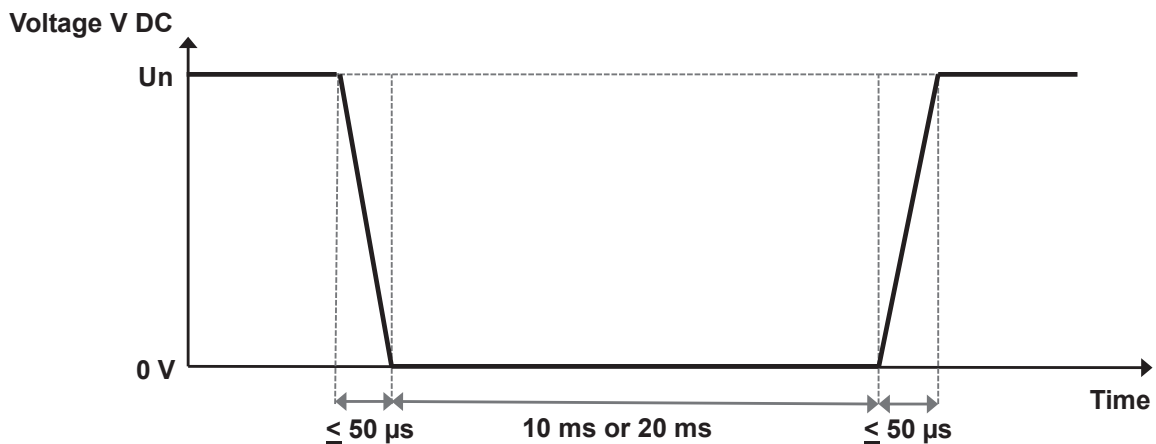

6 APPLICATIONS

All electrical equipment used on rolling stock must meet the standard EN50155, equipment installed will mostly be powered from the DC battery bus voltage, which will require a DC/DC converter that is able to meet the requirements of EN50155. (Note – the DC/DC converter is not approved to EN50155 in its own right, as it is a component within the final application, but must meet the requirements for Voltage transients and Environmental, so when it is included as a component in a system/application, the end equipment will meet EN51055). Below is a typical list of applications where a rail compliant DC/DC converter will typically be used.

FIGURE 7 Typical Rolling Stock Applications

Application	Location	Power Level (Typical)
Smoke detector	Passenger Carriage	50w
CCTV	Passenger Carriage	200w
Infotainment	Passenger Carriage	200w
Visual Displays	Passenger Carriage	300w
Emergency Lighting	Passenger Carriage	300w
Door opener	Passenger Carriage	300w
PA (Passenger announcement)	Passenger Carriage	100w
Wi-Fi / 4G	Passenger Carriage	250w
Windscreen Wiper	Driver Compartment	300w
Communications System	Driver Compartment	150w
Sensors	Locomotive	100w
Headlights	Driver Compartment	300w
Braking System	Locomotive	300w
Engine Management	Locomotive	200w
Positive Train control	Locomotive	200w

There are numerous more applications, some lower power and some higher power, but the general spread of power requirements range from 10w – 1000w, with the medium cc 100w – 300w.

FIGURE 8 Typical Rolling Stock Applications

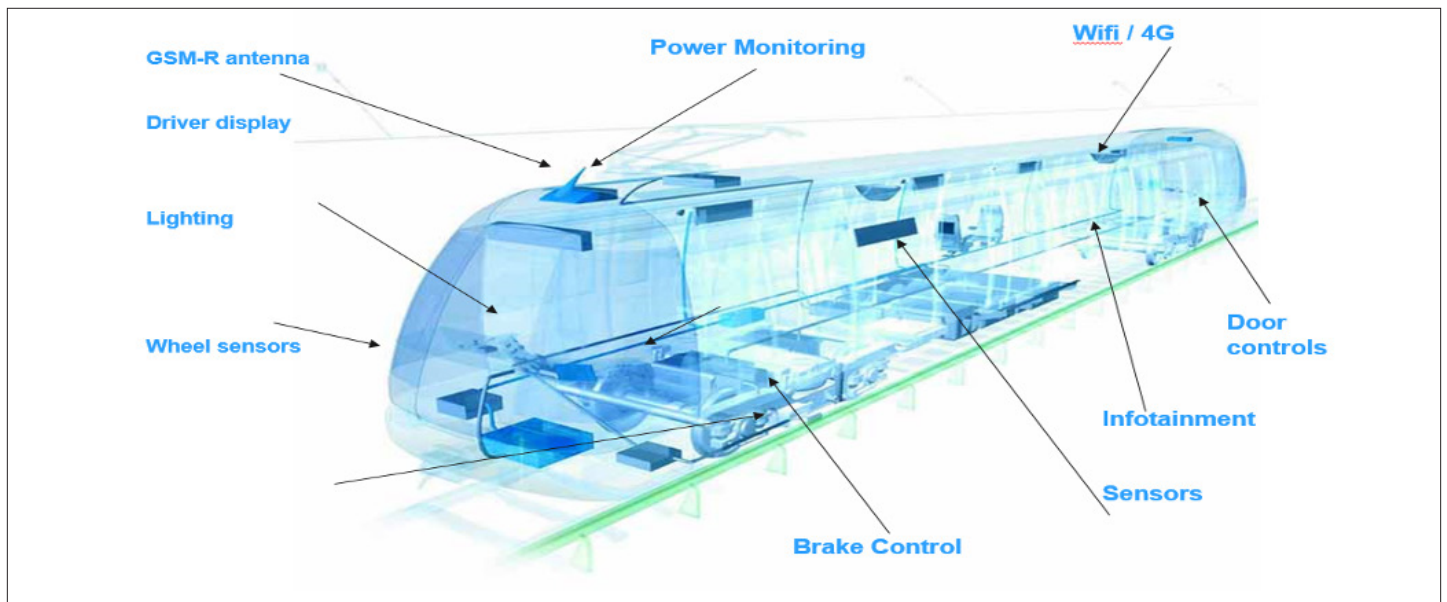

7 TYPES OF DC/DC CONVERTERS

There are two main styles of DC-DC converters used on rolling stock applications: embedded style converters as shown in fig 9, these board mount style converters are designed to be soldered onto a PCB within the application embedded in the assembly. These types of converters will meet the Voltage Transient range of EN50155, Environmental requirements, but will need additional EMI circuitry to meet the requirements of EN50121-3-2 and will also need consideration for thermal cooling to ensure the DC/DC is operated within the end equipment operating range.

The other style of DC/DC used on rolling stock is a chassis mount style converter, these converters cover all the requirements of EN50155 including EMI and can be considered a “black box” solution, taking away any design work required to meet EN50155, typically having easy to use connectors and simple installation with minimal design work. (Fig 10.)

FIGURE 9 Embedded Style DC/DC Converter

Murata IRx Series

<https://www.murata.com/en-us/products/productdetail?partno=IRH-24%2F10.5-W80NB-C>



FIGURE 10 Chassis Mount Style Solution

Murata IRV300

<https://www.murata.com/en-us/products/productdetail?partno=IRV300-24W80-C>



8 EMISSIONS LIMIT LEVELS

Conducted emissions limits are in accordance with EN50121-3-2 (2016) which are:

150kHz – 500kHz = 99dBuV Quasi Peak / 89dBuV Average
 500kHz – 30MHz = 93dBuV Quasi Peak / 83dBuV Average

(+10dB limit allowance above EN55011 limit levels)

For Radiated emissions limits are in accordance with EN61000-6-4 which are:

30MHz – 230MHz = 40dBuV Quasi Peak
 230MHz – 1GHz = 47dBuV Quasi Peak

9 IMMUNITY LIMIT LEVELS

Immunity standards are in accordance with BS EN50121-3-2:2016, which call up the EN61000-4 series of sub standards.

Fast Transient Bursts:	EN61000-4-2(2009)	Contact Discharge +/- 6kV Air Discharge +/- 8kV
RFI Electromagnetic Field:	EN61000-4-3(2006)	80MHz – 6GHz (3v RMS to 20v RMS)
Fast Transient Bursts:	EN61000-4-4(2012)	+/- 2kV
Surge	EN61000-4-5(2014)	+/- 2kV Common Mode +/- 1kV Differential Mode
RFI Common Mode	EN61000-4-6(2014)	150kHz – 80MHz 10v RMS.

10 FILTER DESIGN

In this section we begin to investigate deeper into the design of a suitable EMI filter for a typical rail application according to EN50121-3-2.

10.1 INPUT CURRENT

The overall objective of this filter is to meet the requirements set out in EN50155 for conducted emissions and the immunity requirements – as per section 9.

For the filter circuit example, we assume a DC/DC converter has an input voltage range of **16v – 160v** with **250w** of output power, and a switching frequency of **240kHz**. The efficiency of the DC/DC worse case is **87%**.

Therefore, the maximum input current will be:

EQUATION 1 Input Current

$$\frac{OP \frac{Power}{efficiency}}{V_{min}} = Input\ Current \quad \frac{\frac{250W}{0.87}}{16v} = 18A$$

This means any inductors, connectors, fuses, PCB traces must be able to operate at a minimum of 18A. Deration guidelines and thermal deration must also be factored. Also, the input voltage transient range must operate at 14.4v for 100mSec.

10.2 IMMUNITY

FIGURE 11 IMMUNITY SCHEMATIC

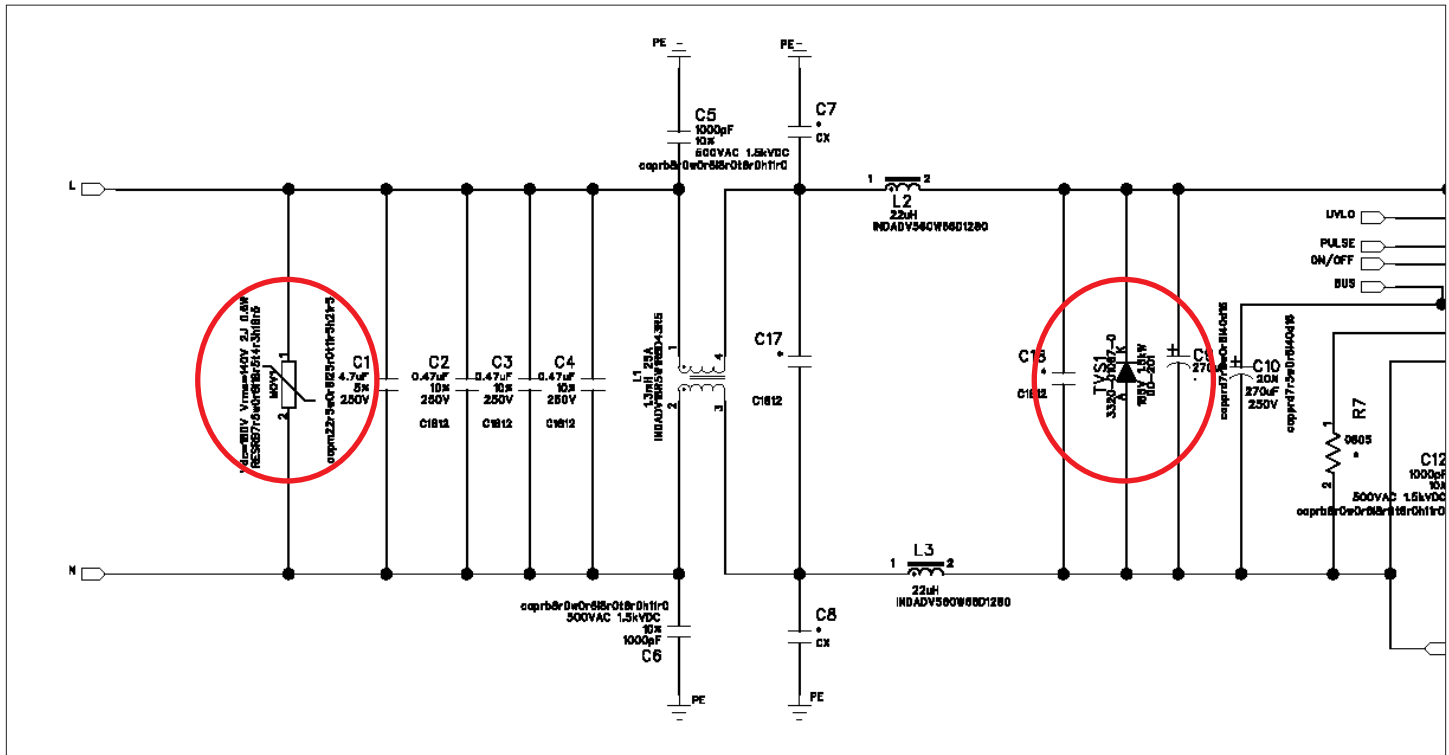

Components MOV1 and TVS1 as highlighted above are included for immunity protection.

MOV1 is a Metal Oxide Varistor that is a non-linear surge suppressor, TVS1 is a silicon tranzorb. The purpose of both devices is to trigger into conduction mode upon the detection of a surge, transient or ESD event, suppress the event and then return to normal mode operation and prevent the transient damaging other circuitry i.e. DC/DC converter (4).

The MOV is positioned directly at the input as it exhibits a higher dynamic resistance and slower turn on characteristic that lends itself well to front line surge events, the tranzorb is positioned after the common mode choke L1 and Diff chokes L2, L3 as it provides a much sharper dynamic resistance resulting in quick trigger conduction of any transients passing through after the MOV, the inductors provide a resistance path also reducing the transient level.

The MOV is chosen based on the following parameters.

The maximum input operating voltage of the circuit is 160vDC, allowing for a 10% headroom on the max voltage = 180vDC. The source impedance is 42ohm so the power of the device will be - $V \times I \times t = 1820v \times 43A \times 50\text{usec} = 3.9j$. (These pulses are applied positively and negatively for a min of 5 in each polarity).

The Tranzorb chosen is 185vDC 1.5kW rated device.

Note that the input capacitance directly at the input to the DC/DC 270uf electrolytic capacitor also has a resistive damping effect on surge and transients

10.3 COMMON/DIFFERENTIAL MODE FILTERING

Common mode noise is defined as the noise signal that flows simultaneously on both positive and negative power lines, the noise is equal on both lines and is added together to result in common mode noise the noise on each line returns through a common ground.

FIGURE 12 COMMON MODE NOISE

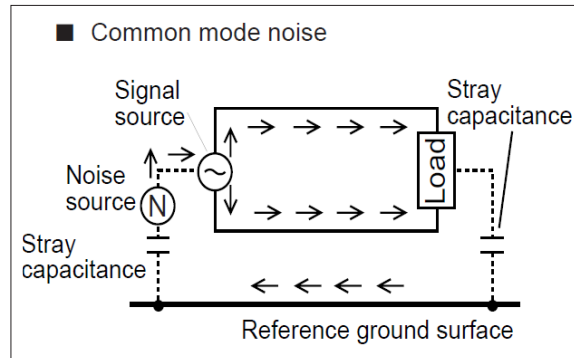
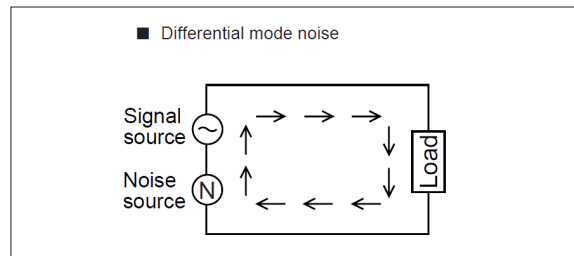

FIGURE 13 DIFFERENTIAL MODE NOISE



Differential mode noise is defined as the noise that appears on two lines of a closed loop that flow in opposite directions, one voltage minus the other voltage is the differential voltage.

When debugging EMI issues, it is important to understand what type of noise you are dealing with, in order to resolve relevant noise issues.

More detailed resource can be found on Murata's web site dedicated to EMI filtering components and techniques. (6)

10.4 IMPEDANCE

It is important that the output impedance of the proposed filter is less than the input impedance of the DC/DC converter to prevent oscillation and resonance as per Middlebrooks theorem (usually by a factor of 10).

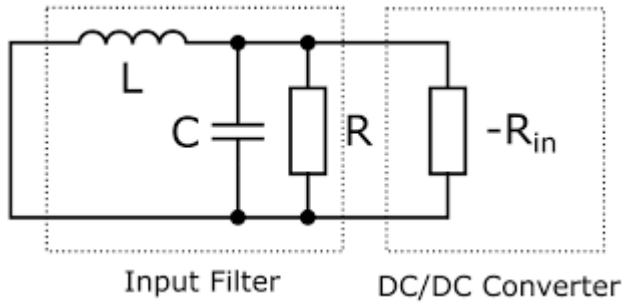

To calculate the input impedance of the DC/DC we use formulae:

EQUATION 2 Input Impedance

$$Z_{in} = V_{in}^2 \times \eta / P_{out}$$

To calculate the output impedance of a filter equation below is used.

EQUATION 3 Output Impedance

$$Z_o = \sqrt{\frac{L}{C}}$$

So, for example if the input impedance of the DC/DC converter is 10ohm, then the output impedance of the filter should be 1ohm or less.

10.5 FREQUENCY CUT OFF

We need to determine the Cut Off Frequency (F_{co}) of the filter design.

The F_{co} is the point on the bode plot where the filter transitions from a pass filter to a stop filter, i.e. starts to attenuate nominally -3dB of the pass band value.

FIGURE – BODE PLOT SHOWING F_{CO}

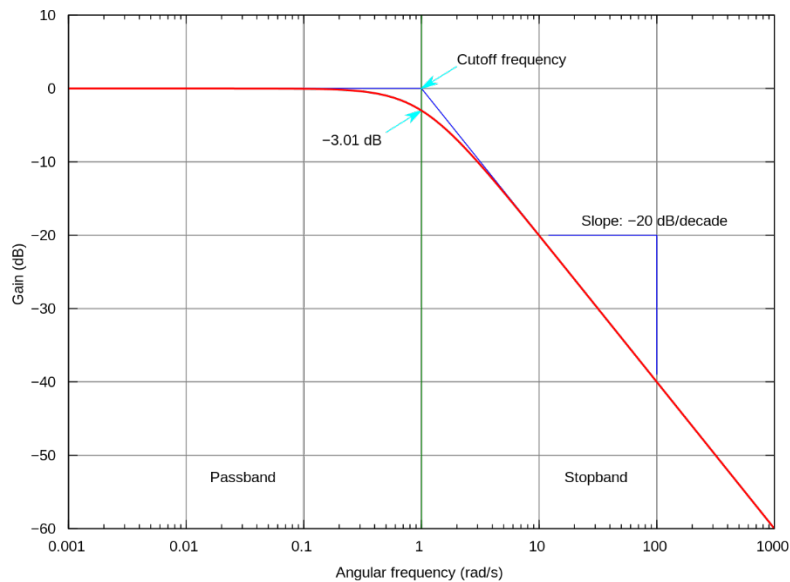

EQUATION 4 Frequency Cut off

The equation for F_{co} =

$$F_{co} = \frac{1}{2\pi} \sqrt{LC}$$

Fundamentally we need to know what the maximum dBuV level is of the standard we are looking to meet, and the harmonic currents generated by the DC/DC. This can be done by simulation, measurement or calculation.

We are looking for the value of the Gain of the harmonic at the switching frequency of the converter, which can be simply calculated as follows:

EQUATION 5 Gain

$$Gain = \sqrt{\text{Amplitude after filter}} \div \text{Amplitude before filter}$$

From this value we can simply use: $F_{co} = Gain \times Freq (s)$

10.6 Q DAMPING FACTOR

The Q factor of an EMI filter is the resonance that occurs because of L & C in the circuit, the component values cause a peak resonance effect at f_{co} . If left uncontrolled this will cause instability and peak noise at that frequency. We suppress the Q factor with a series damping resistor, ideally looking for a value of $Q=1$.

The equation used to calculate the Q factor is:

EQUATION 6 Q Factor

$$Q = \frac{1}{R} \sqrt{\frac{L}{C}}$$

Note that the input electrolytic capacitor of the DC/DC converter has an inherent series resistance, which should be considered when calculating the Q value, sometimes this value is enough for this purpose.

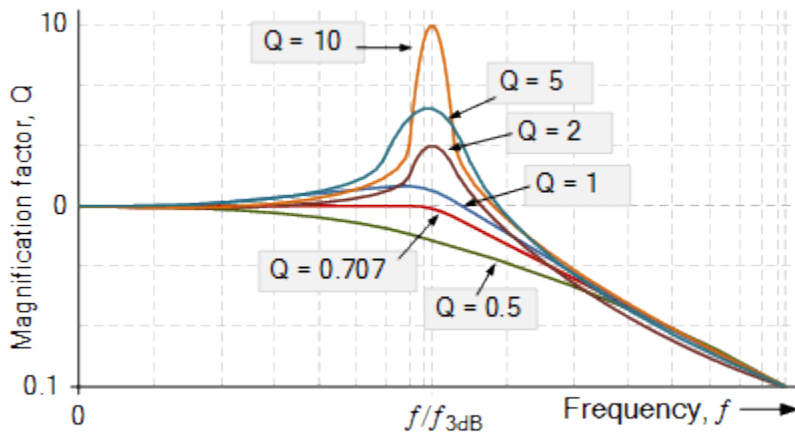

11. DIFFERENTIAL MODE FILTER DESIGN

We now have all the info we need to start designing an EMI filter.

Specifications:

DC /DC has **250w** output power at an efficiency of **90%**, it has a switching frequency of **240KHz** and an input voltage range of 16v – 160v DC. Filter design for this example will be done at the Vnom of the battery supply **110v**.

11.1 DIFFERENTIAL MODE FILTERING

Design of the differential mode section begins with adding an LC filter directly to the input of the DC/DC converter, the differential inductor value needs to be balanced between the two lines, which means two separate inductors. There is always a bulk capacitor directly at the input of the DC/DC converter which ensures stability of operation of the converter, and to add input source impedance to prevent instability with the input filter or input source and cables etc. The inherent ESR of this capacitor can substitute of count towards the value of the Q damping resistor.

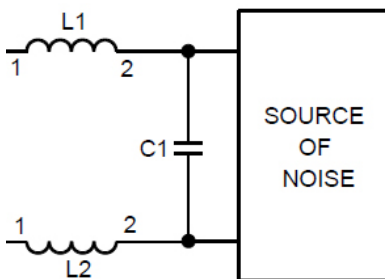

11.1.2 IMPEDANCE CALCULATION

Input Impedance of the DC Converter. Equation 2 =

$$\begin{aligned} Z_{in} &= V_{in}^2 \times \eta / P_{out} \\ &= 110^2 \times 90\% / 250w \\ &= \underline{43 \text{ Ohms}} \end{aligned}$$

Using Middlebrook theorem the output impedance of the filter should be = 1/10 of the input impedance of the DC/DC for stability. = 4.3 Ohms.

11.1.3 GAIN CALCULATION

EQUATION 3 Gain =

$$\begin{aligned} \text{Gain} &= \sqrt{\text{Amplitude after filter} \div \text{Amplitude before filter}} \\ &= \sqrt{\frac{1.8mA}{1000mA}} = \underline{0.0424} \end{aligned}$$

11.1.4 FREQUENCY CUT OFF CALCULATION

EQUATION 7 Frequency Cut Off / Gain

$$\begin{aligned} F_{co} &= \text{Gain} \times \text{Freq} \\ &= 0.0424 \times 240kHz = \underline{10kHz} \end{aligned}$$

11.1.5 L & C CALCULATION USING IMPEDANCE PAPER.

Now that we have calculated the impedance and frequency cut off, we can substitute these values onto an impedance paper to produce the results for L & C.

By Using an Impedance paper (8), we can easily calculate and manipulate different values of components easily by using the parameters for Fco & Impedance. The values shown are 4uF min capacitance and 50uH maximum inductance. Remember to split the inductance value across each line. (9)

FIGURE 14 Impedance Paper

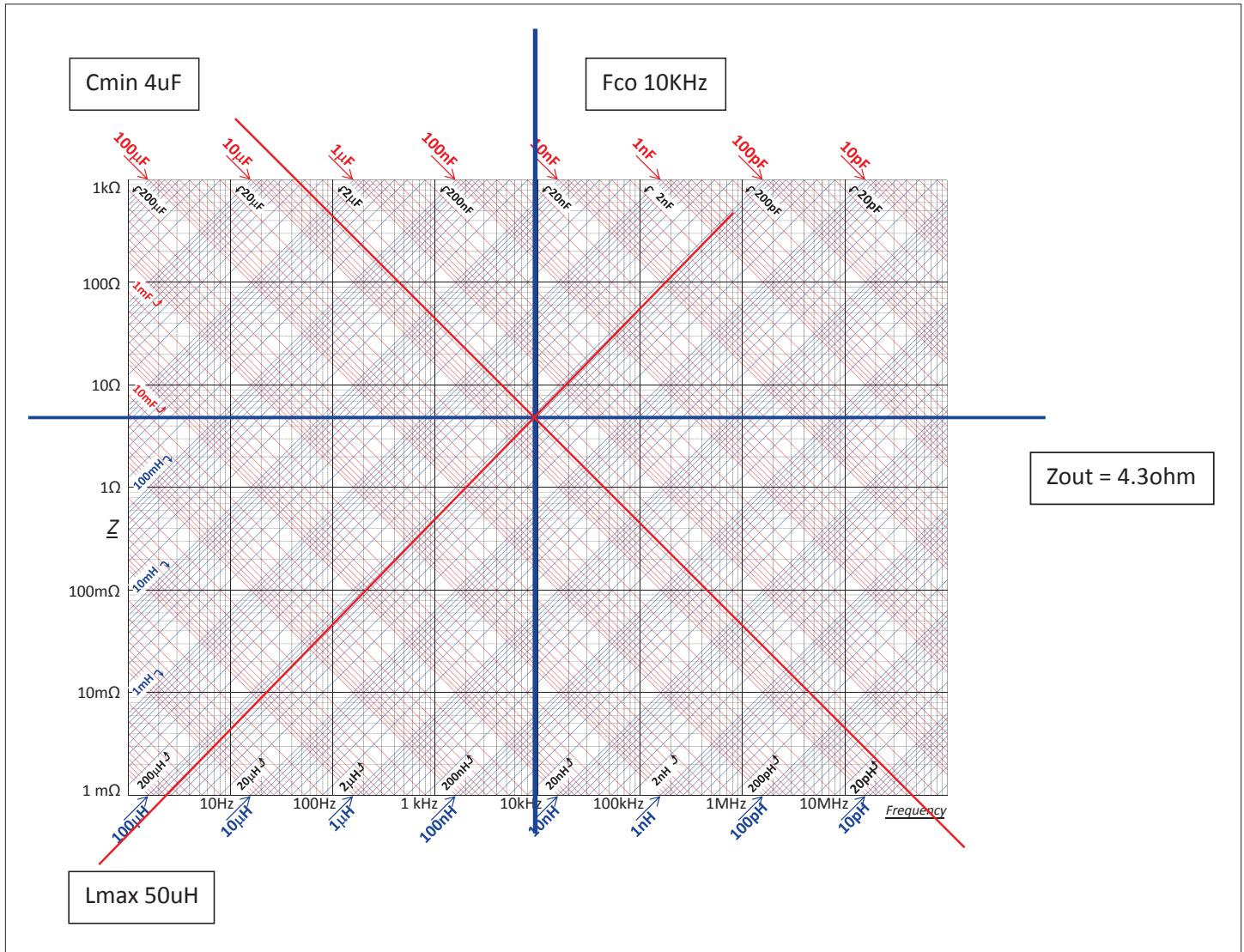

11.1.6 DAMPING RESISTOR CALCULATION

Now that we know the values of L & C we can calculate the damping resistor.

EQUATION 6 Q Factor

$$\sqrt{\frac{L}{C}} = \sqrt{\frac{50}{4}} = \underline{3.5 \text{ Ohm.}}$$

Remember to factor in the ESR of the input capacitor. (sometimes this is enough for the damping resistor).

11.1.7 DIFFERENTIAL FILTER.

The final calculated circuit =

FIGURE 15 Differential Filter Schematic

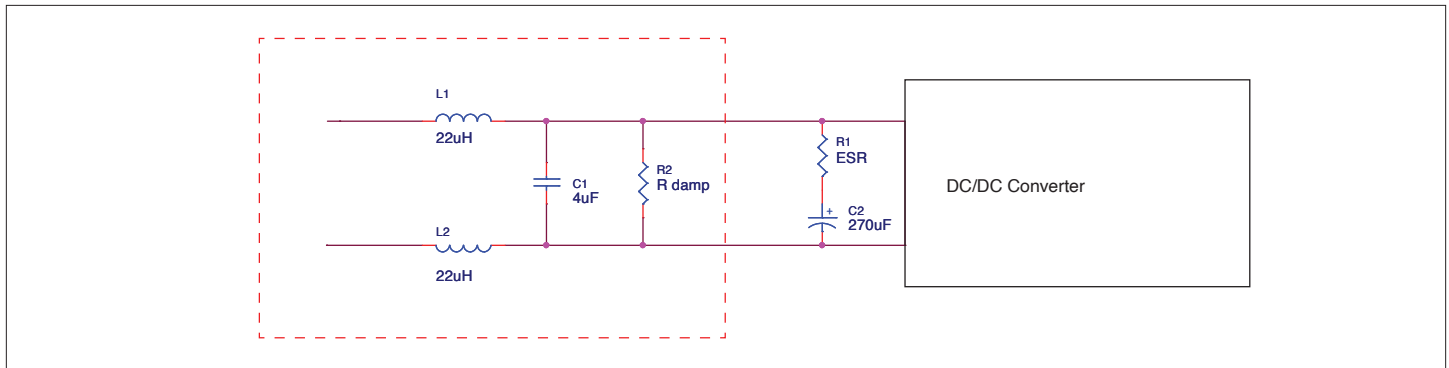

12. COMMON MODE FILTER DESIGN

12.1.1 CM CHOKE DESIGN

Now we look at the Common mode components. Common mode noise is prevalent around 5MHz and above, so choosing the value of L & C is based around this figure. Common mode chokes have a parasitic amount of differential mode inductance, depending upon the calculation from the last cct, you can choose a value of CM choke based upon its parasitic differential mode characteristics to satisfy that aspect and be left with the CM mode value. It's important to check the current rating of the choke across the input voltage and temperature range. If the differential inductance of the CM choke is not enough for the calculated DM inductance, then additional differential chokes must be used.

In this example we chose a 1mH 5A CM choke that had a differential inductance of 10uH, so an additional 40uH differential inductance was chosen (2 x 22uH preferred values).

12.1.2 Y CAPACITORS

In order to suppress common mode noise to ground, there must be some capacitive path to ground after the CM choke, this forms the basis of an LC filter.

As the filtering is above 5MHz we know that the Fco of the CM filter is approx. 50kHz.

EQUATION 8 Frequency Cut Off CM

$$F_{co} = \frac{1}{2\pi\sqrt{LC}}$$

Rearranging for C =

$$C = \frac{1}{(F_{co}2\pi)^2 L}$$

= 10nF. This is split into two (2 caps) = 4n7 preferred value.

12.1.3 X CAPACITOR

As a rule of thumb, the X cap must be less than 1/5th of the output cap of the filter. The cap in our differential calculation was 4uF, so we should be >800nF approx. (820nF preferred value).

It is also important to ensure that the cap is not within the resonance region of the filter. There are equations to calculate this depending on the source impedance being used.

FIGURE 16 Common Mode Filter Schematic

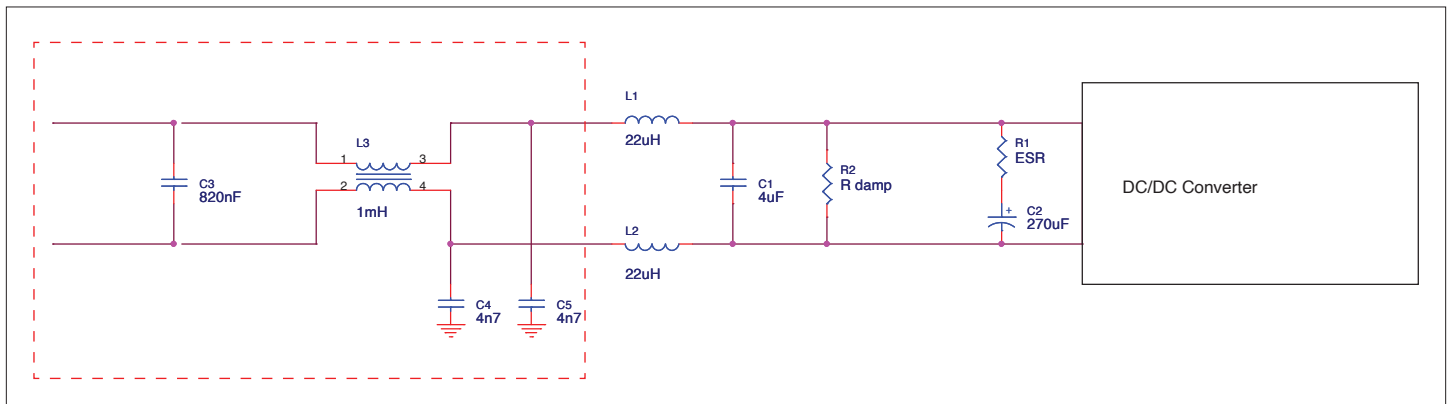

13 CONCLUSION

The EMI filter design example shown, is a pure theoretical calculation, and can be used for all types of DC/DC converters (not just for railway applications). However in real life situations other factors can have a large influence on the outcome inc: PCB layout design, parasitic effects of components and test measurement set up.

The overall EMI calculations for the filter above are used on the available evaluation board design for the Murata IRHW80, IRQW80 DC/DC converters (10).

Remember that EMI is not an exact science and not one rule can be applied for all situations, EMI filter design is an iterative process that requires fine tuning of the selected components and their inherent parasitic values to finalise the design of a suitable filter.

It is also worth noting that the testing of the filter design is carried out using fixed resistive loads, where in a typical real-life application the loads can be transient and variable in nature, also affecting the performance of the filter.

14 APPENDICES

14.1 APPENDIX 1 EVAL BOARD SCHEMATIC & BOM

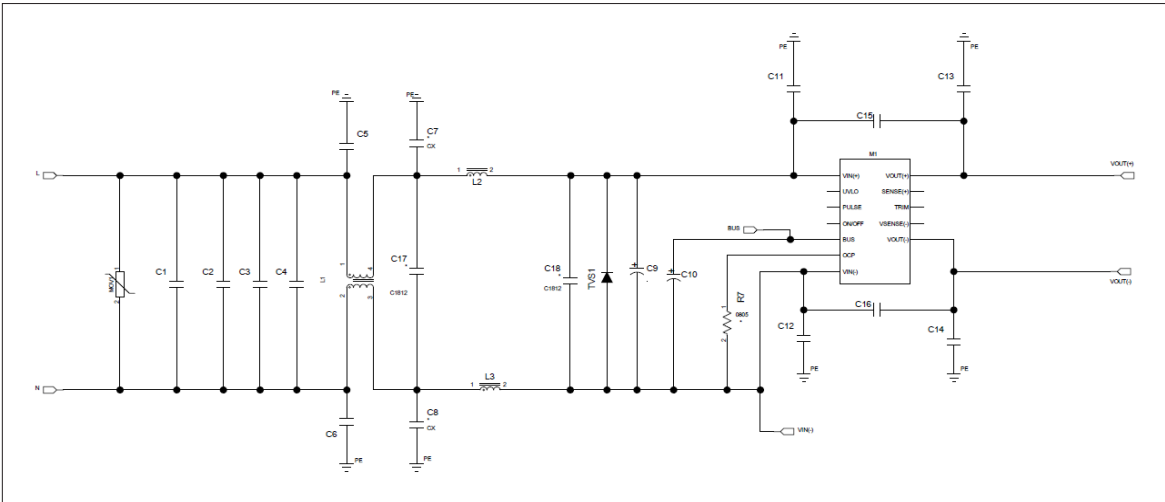

Reference	Manufacturer	MPN	Type	Specifications	Qty
MOV1	Epcos	B72214S0141K101	Varistor	180V, 36J	1
TVS1	Littell Fuse	1.5KE220A	TVS diode	185V, 1.5KW	1
C1	Faratron	C212E475K9AC000	Polyester capacitor	250V, 4.7uF	1
C2, C3, C4	Murata	GRM43DR72E474KW01L	Capacitor MLCC	250V, 0.47uF	3
C5, C6, C11, C12, C13, C14	Murata	DE1E3RA102MA4BQ01F	Safety ceramic cap	500V, 1000pF	6
C9, C10	NCC	EKXJ251EXX271ML40S	E-cap	250V, 270uF	2
C15, C16	Murata	DE1E3RA472MA4BQ01F	Safety ceramic cap	500V, 4700pF	2
L1	Würth	7448262013	CM choke	1.3mH, 20A	1
L2, L3	Bourns	2300HT-220-V-RC1951	DM choke	22uH, 19A	2
C7, C8	NA	NOT USED	NA	NA	0
C17, C18	NA	NOT USED	NA	NA	0

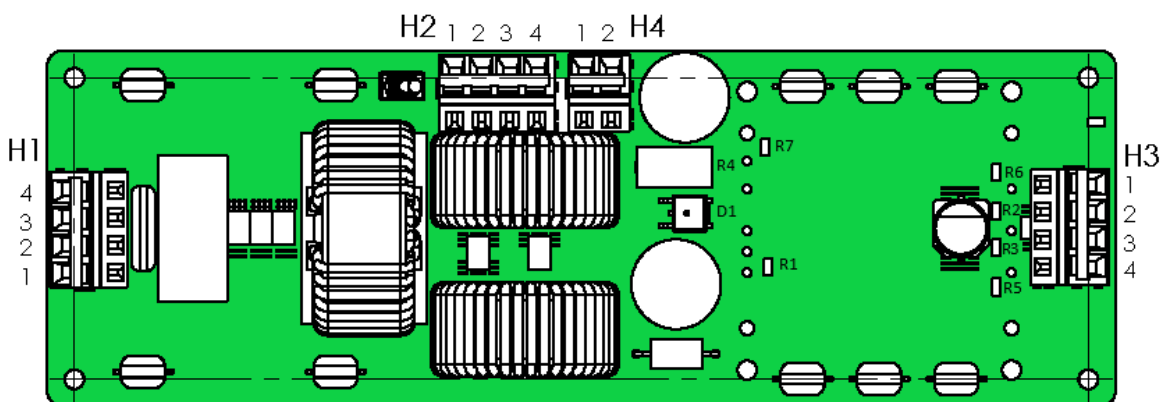

15 REFERENCES

- 1 Cenelec (2017): BS EN50155:2017 *Railway Applications-Rolling Stock – Electronic Equipment*. BSI Standards Ltd, ISBN 978 0 580 82911 6.
- 2 The Railway Technical Website (2019) available online. <http://www.railway-technical.com/trains/rolling-stock-index-l/train-equipment/> [accessed 06/20].
- 3 TDK S10V Metal Oxide Varistors (2018): *Leaded Varistors Standard Series* https://www.tdk-electronics.tdk.com/inf/70/db/var/S10V_Leaded_StandarD.pdf
- 4 Infineon (2012): *Effective ESD protection design at system level*. https://www.infineon.com/dgdl/AN210_v1_3.pdf?fileId=db3a30432cd42ee3012cee8d005b0c19
- 5 Murata (2020): *Common Mode and Differential Mode noise*. <https://www.murata.com/~media/webrenewal/products/emc/emifil/knowhow/26to30.ashx>
- 6 Murata (2020): *Noise suppression basic course*. <https://www.murata.com/~media/webrenewal/products/emc/emifil/knowhow/26to30.ashx>
- 7 Murata Power Solutions (2020): *IRHW80 data sheet*. <https://www.murata.com/en-us/products/productdetail?partno=IRH-12%2F21-W80NB-C>
- 8 Biricha Digital (2020): *Impedance Paper*. https://www.biricha.com/uploads/8/9/8/0/89803127/printable_z_paper_20181001.pdf
- 9 Biricha Digital (2020): *Differential Mode EMC Filter Design* available online. <https://www.biricha.com/technical-videos.html>
- 10 Murata (2020): *User guide MP-HW80EVAL-01*. <https://www.murata.com/~media/webrenewal/products/power/appnote/dcan-70.ashx?la=ja-jp&cvid=20210205092731000000>