



PRODUCT OVERVIEW

MWOCP68-3600-B-RM is a highly efficient 80PLUS® Titanium certified, ORV3 3,600 W front-end power supply module featuring a 50 Vdc main output and a 12Vdc standby output. The 50V main output provides active current sharing together with output droop control for up to 21 .6 kW (18 kW in N+1 configuration) when deployed in Open Compute compliant shelves from Murata. This power supply module can be hot-swappable, recovers from over temperature faults, and provides hardware status LEDs and signals. PMBus™ 1.2 digital communication capability the low profile 1U package and 44.3 W/in³ power density make this power and rack solution ideal for delivering reliable power to OCP open rack architecture or stand-alone applications.

FEATURES:

- 80 Plus® Titanium Certified
- Black-Box data-logging capability
- HVAC / HVDC input operation (180-305Vac, 192-400Vdc)
- 50Vdc, 72A main output
- 12V 2.5A standby output
- Nominal Dimensions:
 - 68.0mm (W) x 490.0mm (L) x 40.0mm (H)
 - 2.68" (W) x 19.29" (L) x 1.57" (H)
- 44.3 Watts per cubic inch density (W/in³)
- N+1 redundancy including hot swap capability, up to 18 power modules
- Holdup time:
 - 12 ms at 3600 W and
 - 14 ms at 3000 W output
- Operating ambient temperature: 0 – 50°C
- Integral ORing MOSFETS, both outputs
- Active current sharing together with Droop current sharing for Main output, Droop current sharing for 12VSB output
- Internally cooled by advanced dual rotor variable speed-controlled fan
- PMBus™ / I²C interface monitoring, configuration, and control
- RoHS2 compliant
- PCB card edge interface provided for incoming voltage source connection and DC output in "double-decked" configuration
- 2-year warranty

ORDERING GUIDE				
Part Number	Output power @ highline (180-300Vac & 192-400Vdc)	Main Output	Standby Output	Airflow
MWOCP68-3600-B-RM	3600W	50.5Vdc	12.0Vdc	Front to Back

INPUT CHARACTERISTICS					
Parameter	Conditions	Min	Typ.	Max	Units
Input Voltage Operating Range	AC Voltage	180	230/277	305	Vac
	AC Line Frequency	47	50/60	63	Hz
	DC Voltage	192	240/380	400	Vdc
Turn-on Voltage	AC (Ramp-up)	179	182	185	Vac
	DC (Ramp-up)	182	186	190	Vdc
Turn-off Voltage	AC (Ramp-down)	168	171	174	Vac
	DC (Ramp-down)	172	176	180	Vdc
Maximum Input Current	Vin; 180Vac; 3600W			23.5	Arms
	Vin; 180Vdc; 3600W			23.0	Adc
Inrush Current	Cold Start; <200ms			30	Apk
Efficiency (Excluding Fan Load)	230 Vac; FL		0.99		W/WA
	230Vac; 10% FL	90	92.5		%
	230Vac; 20% FL	94	94.5		
	230Vac; 50% FL	96	96.2		
	230Vac; 100% FL	91	94.5		

¹The power Factor at 20% loading requires to be >0.95 (W/WA) to meet 80 Plus® limits

OUTPUT VOLTAGE CHARACTERISTICS						
Output	Parameter	Conditions	Min	Nom	Max	Units
50V Main	Output voltage	230VAC, no load		51		Vdc
	Output set point accuracy	230VAC, 100% load, Ta=25°C	50.375	50.5	50.625	
	Line and load regulation		50.375		51.25	
	Ripple voltage & noise ¹	20MHz bandwidth			500	mVpp
	Output current	Across AC & HVDC input ranges	0		71	A
	Load capacitance		0		10,000	uF
12VSB	Nominal output voltage			12.0		Vdc
	Output set point accuracy	100% load, Ta=25°C	11.94		12.06	
	Line and load regulation		11.64		12.36	
	Ripple voltage & noise ¹	20MHz bandwidth			240	mVpp
	Output current		0		2.5	A
	Load capacitance		100		3,100	uF

¹ Ripple and noise measured with a parallel combination of 0.1uF ceramic and 10uF low ESR capacitors on the power module respective output. A short coaxial cable connected directly to the input of a scope is required.



OUTPUT CHARACTERISTICS					
Parameters	Conditions	Min	Typ.	Max	Units
Startup time				3	sec
Transient Response ¹	Load step 50%, start from 10%; Slew Rate = 1A/us (min.); 2 ms recovery time to within regulation	48.875		52.125	V
Output current sharing accuracy up to 6 PSUs in parallel	Percentage of total host system load current/number sharing units	50% to 100% of FL	-5	+5	%
		20% to <50% of FL	-10	+10	%
Hot Swap Transient	With an equivalent load step of not more than 50% of FL	48.875		52.125	V
Holdup time	3600 W load	12			ms
	3000 W load	14			ms

¹Proper capacitive load may be required to decouple the wiring inductance between PSUs and load.

ENVIRONMENTAL CHARACTERISTICS					
Parameters	Conditions	Min	Typ.	Max	Units
Storage temperature		-40		70	°C
Operating temperature range	Altitude < 1,880m (5,905 ft)	0		50	°C
	Altitude < 3,000m (16,404 ft)	0		40	°C
Storage humidity		5		95	%
Operating humidity	Non-condensing	5		95	%
MTBF (Target)	Per Telcordia SR-332 issue 3 M1C3 @ 40°C & 230Vac	300k			hrs
Shock	10G shock without degradation of performance or mechanical damage to components in operational 30G in non-operational condition Validation testing per IEC60068-2-27; test Ea. 30G, 11msec half-sine, 3 shocks per face, 6 faces.				
Operating vibration	Sine sweep; 5-150Hz, 0.78G; Random vibration, 5-500Hz, 0.78G				
Safety approval	CAN/CSA C22.2 No.60950-1-07, Am.1:2011, Am2:2014 UL62368-1 IEC62368-1 EN60950-1:2006 +A11+A1+A12+A2 CQC GB4943.1-2011				
Input fuse	Dual internal fuses 25A/500V fast blow on the AC line and neutral input connections				
Weight	2.11kg				

PROTECTION CHARACTERISTICS					
Parameters	Conditions	Min	Typ.	Max	Units
Over temperature (intake)	Auto restart	50		60	°C
Main output OCP conditions	180 – 305 V_{AC}	192 – 400 V_{DC}	SMBALERT Delay	PSU Fault Delay	
OC warning threshold	80 A ± 5%	80 A ± 5%	20 sec	None	
OCP1 threshold	83.5 A ± 5%	83.5 A ± 5%	20 sec	>20 sec +100 ms	
OCP2 threshold	95.5 A ± 10%	95.5 A ± 10%	>20 ms	>20 ms +100 ms	
CC mode threshold ²	> 115 A ± 10%	> 115 A ± 10%			
Standby output OCP conditions¹					
OCP1 threshold	3.5 A ± 10%	3.5 A ± 10%	None	>20 sec ¹	
OCP2 threshold	> 4.0A	> 4.0A	None	Immediately ¹	

¹The STANDBY OCP protection shall be non-latching

²Short circuit protection is realized by CC mode + undervoltage protection.

*Repetitive over current with different duty cycle is limited by thermal performance and may be protected by OTP.

*PSU under OCP conditions or Input failure will enter Battery mode by reducing the main output by 3 V before shutdown.

OVP CHARACTERISTICS					
Outputs	Reset conditions	Min	Typ.	Max	Units
Main output	Latching, recycling AC source or toggling PS_ON to reset	52.5	53.0	54.0	V
Standby output	non-latching/Auto recovery	13.0	14.0	15.0	V

ISOALTION CHARACTERISTICS					
Parameters	Conditions	Min	Typ.	Max	Units
Insulation safety rating / test voltage	Input to output - Reinforced	5,000			Vrms
	Input to chassis - Basic	2,500			
Isolation	Output return to chassis	60			Vdc

EMISSION AND IMMUNITY		
Characteristics	Standard	Criteria
Input current harmonics	IEC/EN 61000-3-12	Complies with Class A Limits
Voltage fluctuation and flicker	IEC/EN 61000-3-11	Complies
Conducted emission	FCC47 CFR part15/CISPR 22/ EN55032	Class A with 6dB margin
ESD immunity	IEC/EN 61000-4-2	Level 4 criteria A
Radiated field immunity	IEC/EN 61000-4-3	Level 3 criteria B
Electrical fast transient/burst immunity	IEC/EN 61000-4-4	Level 3 criteria B
Surge immunity	IEC/EN 61000-4-5	Level 3 criteria A
RF conducted immunity	IEC/EN 61000-4-6	Level 3 criteria A
Magnetic field immunity	IEC/EN 61000-4-8	3A/m criteria B
Voltage dips, interruptions	IEC/EN 61000-4-11	ESD immunity 230Vin, 100% load, phase 0°, dip 100% duration 10ms (A) 230Vin, 50% load, phase 0°, dip 100% duration 20ms (12Vmain:B, 12VSB:A) 230Vin, 100% load, phase 0°, dip 100% duration >20ms (B)

RELATED PRODUCTS		
Model	Function	Description
MWOCES-211-P-C	OCP ORV3 Power Shelf	21" x 10U up to 21.6kW OCP V3 Compliant Power Shelf comprised of the Power Shelf, 6PSUs, 1 RMU.

Maximum output surge load level and duration
Surge pattern 1 (Full load = 3,000 W)

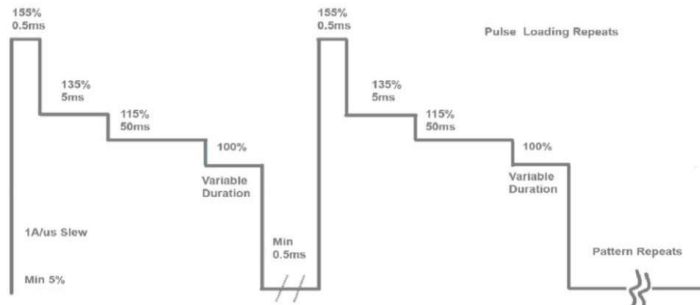

Surge pattern 2 (Full load = 3,600 W)

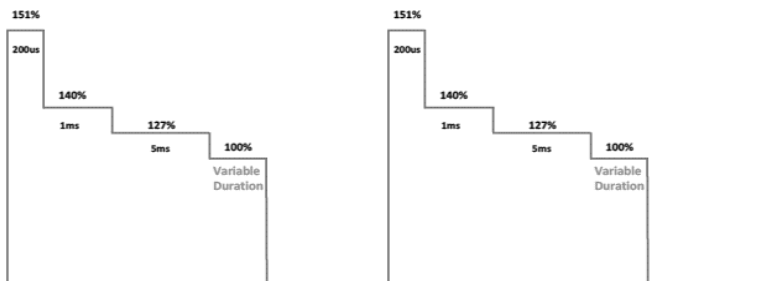

STATUS AND CONTROL SIGNALS		
Signal Name	Description	Interface Details
50V main_REMOTE_SENSE & 50V main_REMOTE_SENSE_RETURN	The remote sense signals are intended can be connected at point of load. The power module senses this remote output voltage and can compensate for up to 0.3Vdc of voltage drop due to resistive losses caused by the load current and associated connection. For best performance, the remote sense lines should be routed away from noise sourced and be twisted together if using a harness.	
VIN_GOOD	This active high signal Indicates incoming source voltage (AC or DC) is valid	Link to interface details
PWOK	Power Okay signal Indicates all outputs are valid and without faults	Link to interface details
SMBALERT_L	This signal asserts (low state) to indicate to the host/system that a fault condition has been detected within the power module. This signal asserts coincident with the setting of any supported PMBus™ status_x register fault bit flags. Refer to ACAN-109 for details	Link to interface details
SCL, SDA	Clock (SCL) and data (SDA) serial digital lines, compatible with PMBus™ Power Systems Management Protocol Part 1 – General Requirements Rev 1.2 and includes 45p internal capacitance.	Link to interface details
SIGNAL_RETURN	Signal return is the reference point for all signals and is separate from the main output return.	signal ground must be externally connected to 12VSB_RETURN (at system side)
I_SHARE	This signal is connected between sharing units forming a current share bus. It is an input and/or an output (bi-directional analog bus) as the voltage on the line controls the current share between sharing units. A power module will respond to a change in this voltage and a power supply can also change the voltage depending on the load drawn from it. On a single unit, the voltage on the pin (and the common ISHARE bus) would read approximately 8VDC at 100% load (single power module capability). For two identical units sharing this same 100% load this would read approximately 4VDC for perfect current sharing (i.e. 50% module load capability per power module).	
12VSB_RETURN	Standby output return is an independent return for the signal reference and is internally connected to VSB Return and Main Output Return.	signal ground must be externally connected to 12VSB_RETURN (at system side)
PSKILL	This signal is used for internal power module power processing to ensure glitch-free operation during power module insertion or extraction into/from host/system and is internally pulled up. This signal must be connected to signal return at system side and is provided on shortest pin (last to make, first to break contact). The main 50V output is enabled upon detecting the low state and disabled when a low state is no longer detected.	Link to interface details
PS_ON_L	Provides remote on/off control of the main 50V output. This signal is internally pulled up. The main output is turned on when this signal is externally connected to signal return and off when not connected to signal return.	Link to interface details
PS_A2	PMBus™ address selection pins for the power module; These pins can be shorted to signal return or pulled up externally to logic high state to set the desired PSU target device PMBus address. Refer to ACAN-109 for details.	Link to interface details
PS_A1		
PS_A0		
PRESENT	The signal is used to detect the presence (installation) of a power module by the host system.	Link to interface details

TIMING SPECIFICATIONS

TIME REFERENCE	DESCRIPTION	MIN	MAX	UNITS
T1	Delay from 12V _{SB} regulation to 50V _{DC} output turn on.	1500	1700	ms
T2A	Main 50V _{DC} rise time	2	100	ms
T2B	12V _{SB} rise time	2	20	ms
T3	Delay from Main 50V _{DC} output within regulation to PWOK assertion at turn on	100	500	ms
T4	Delay from PWOK de-assertion to Main 50V _{DC} dropping out of regulation. (For input on/off only, not applicable to output fault protection)	1		ms
T5	Delay from Main 50V _{DC} out of regulation to 12V _{SB} turn off.	5		ms
T6	Delay from loss of INPUT to PWOK de-assertion	10		ms
T7	Delay from application of INPUT on to Main 50V _{DC} turn on		3000	ms
T8	PS_ON negation (PSU off) to PWOK negation		2	ms
T9	PS_ON (PSU on) to output established		350	ms
T11	Delay from VIN drop out to VIN_GOOD negation & SMBALERT assertion		2	ms
T12	Delay from VIN GOOD to PWOK	1		ms

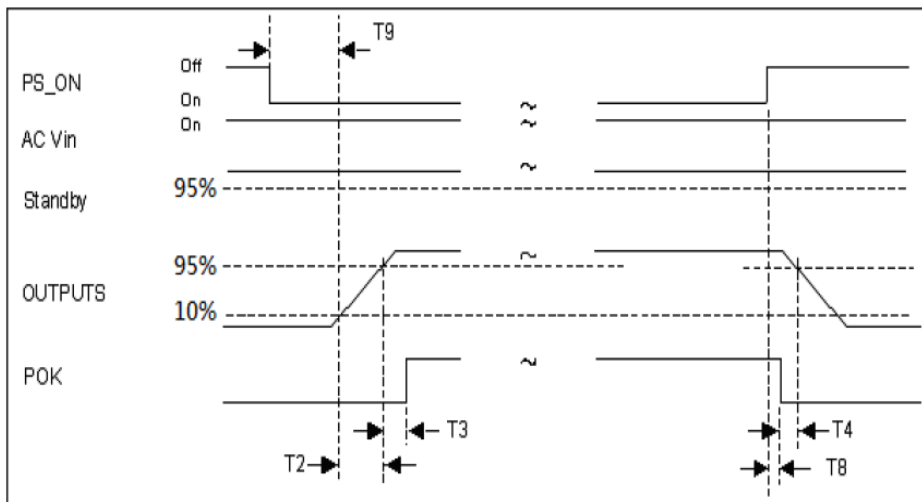
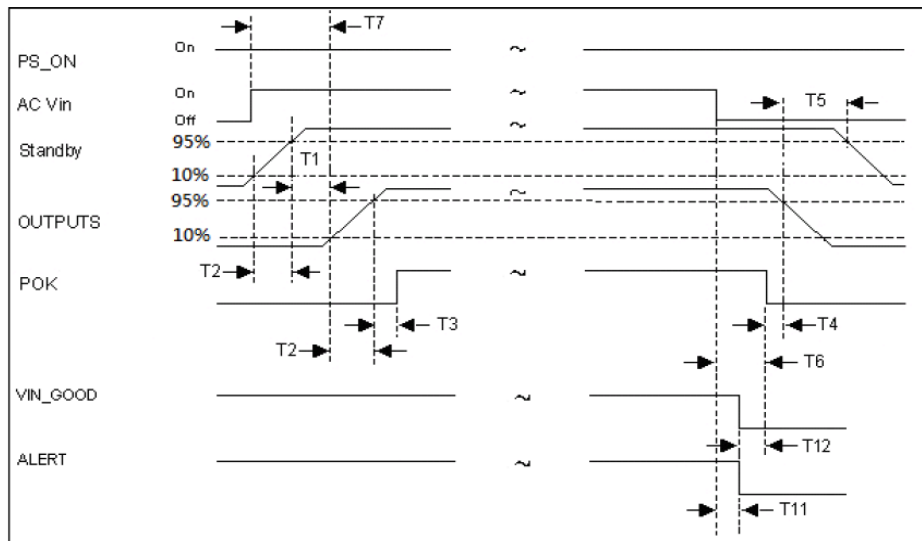

INPUT, OUTPUT/SIGNAL INTERFACE DETAILS

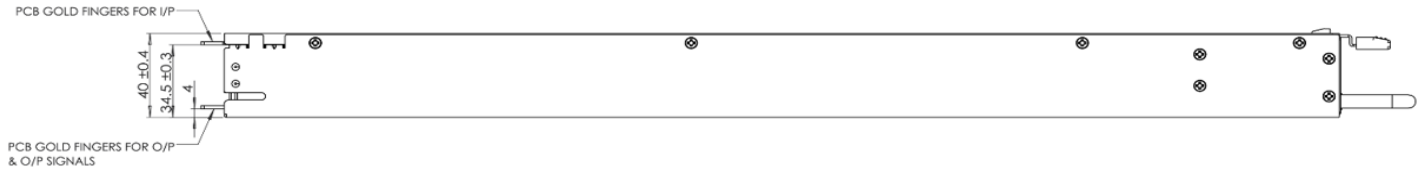

Power Supply module Side INPUT CARD EDGE:

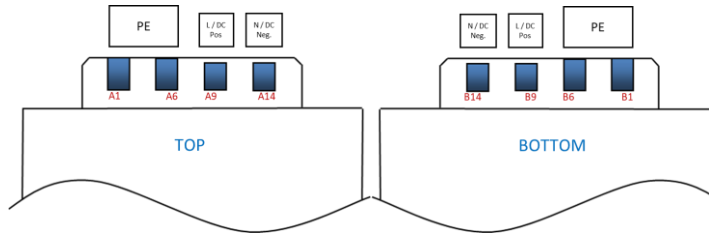

Power Supply module Side Output Card Edge:

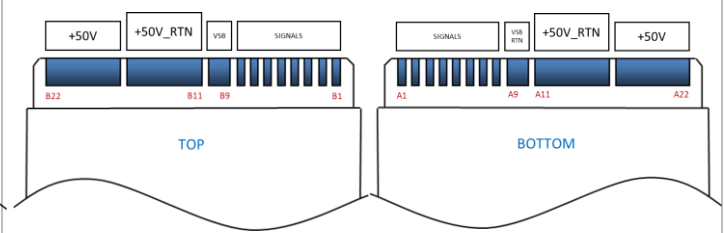

Mating Connector (System Side) FCI 10035388 Series

FCI Dimensions

FCI Recommended PCB Layout

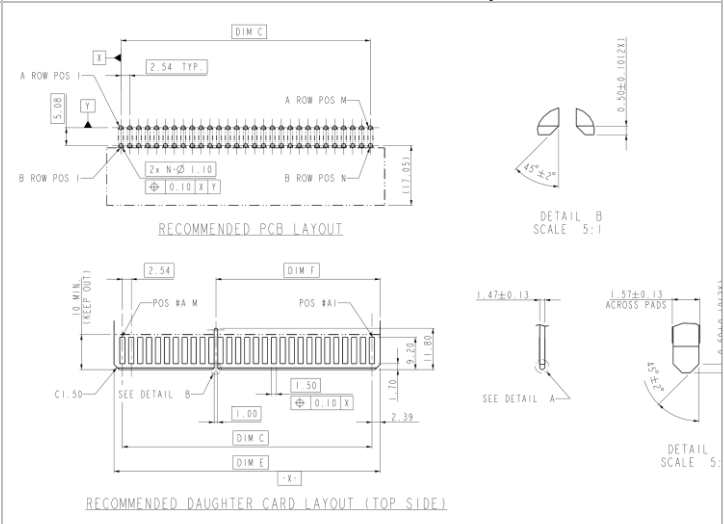
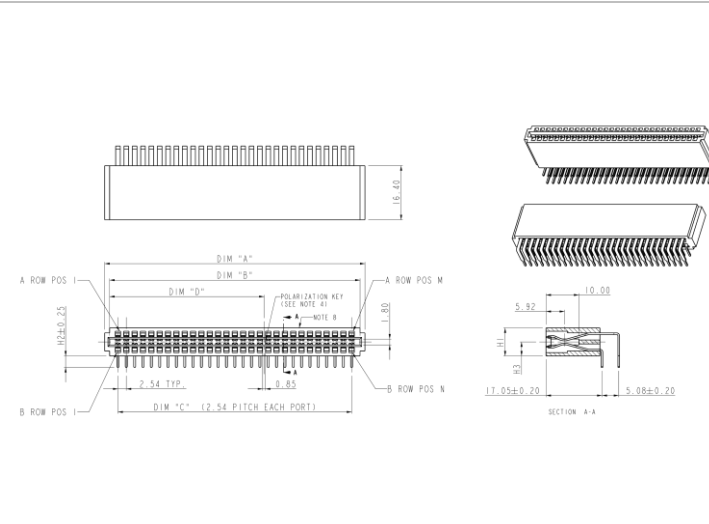

¹ FCI details about shown for illustration purposes; refer to the FCI's connector datasheet for fine details and specifications

Mating Connector (System Side): FCI Power Edge Card Series:

Mating Connector (System Side): FCI Power Edge Card Series:

PRAT NO.	DIM"A"	DIM"B"	DIM"C"	DIM"D"	DIM"E"	DIM"F"	H1	H2	H3	PIN CONFIGURATION	M	N
10035388-126 10035388-126L1	41.10	38.10	33.02	N/A	37.00	N/A	8.50	3.50	4.25	47 POS (1-30) + 30P (31-64) 61 POS (1-30) + 30P (31-64)	14	14

PRAT NO.	DIM"A"	DIM"B"	DIM"C"	DIM"D"	DIM"E"	DIM"F"	H1	H2	H3	PIN CONFIGURATION	M	N
10035388-400 10035388-400F	61.42	58.42	53.34	29.21	58.12	29.06	8.50	3.50	4.25	ALL LOADED	22	22

INPUT POWER INTERFACE CARD EDGE “GOLD FINGER” PIN ASSIGNMENT

Signal	No. of pins	Pin assignment	Description
Input Neutral	4	A13-A14 / B13-B14	Incoming Neutral/L2 or HVDC Negative connection; Dual fusing allows for phase connection of suitable voltage rating
Input Live	4	A9-A10 / B9-B10	Incoming line/phase or HVDC Positive connection; Dual fusing allows for phase connection of suitable voltage rating
EARTH	4	A1, 2, 5, 6	Protective ground
EARTH	4	B1,2,5,6	Protective ground

OUTPUT, SIGNAL INTERFACE CARD EDGE “GOLD FINGER” PIN ASSIGNMENT

Signal	No. of pins	Pin Location	Description
12VSB	2	B9, B10	12V “Standby”; 12VSB “+VE” output connection
I_SHARE	1	B6	An active analogue current share “bus” directly connected between sharing power modules
REMOTE_SENSE_RETURN	1	B7	Compensation of voltage drops caused by resistive losses to the load
12VSB_RETURN	2	A9, A10	12V “standby Return”; 12VSB_RETURN & SIGNAL_RETURN must be shorted together at system side
+50V_REMOTE_SENSE	1	B8	Compensation of voltage drops caused by resistive losses to the load
PSKILL	1	A4	Power module kill pin; used during insertion and extraction during “hot swap” of the power module; shortest sequenced pin, Last to Make, First to Break (LMFB) contact
VIN_GOOD	1	A2	Input source voltage present and within operational limits
PS_ON_L	1	A3	Remote ON/OFF (enable/disable) of the 50V Main output
PWOK	1	A1	All outputs are present valid and exhibit no faults (within operational limits)
SMBALERT_L	1	B2	An alert (interrupt) issued to the host system in response to a warning of fault condition raised in the power module
PS_A2	1	B3	I2C bits to allow addressing of slave devices operating on the PMBus™ (Power Management Bus protocol).
PS_A1	1	B4	
PS_A0	1	B5	
SCL	1	A7	Serial clock (SCL) and data (SDA) lines use for communication with slave PMBus™ slave devices
SDA	1	A6	
SIGNAL_RETURN	1	A8	A signal ground (common) for all signals (including I2C); note that this signal must be directly connected to 12VSB_RETURN at the system connector
PRESENT	1	A5	A passive signal directly connected internally within the power module to SIGNAL_RETURN
50V MAIN_OUTPUT	12	A17-A22, B17-B22	The positive terminal of the main output
50V MAIN_RETURN	12	A11-A16, B11-B16	The return terminal of the main output

MECHANICAL DIMENSIONS

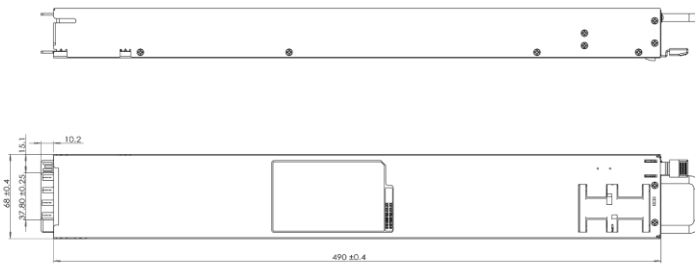
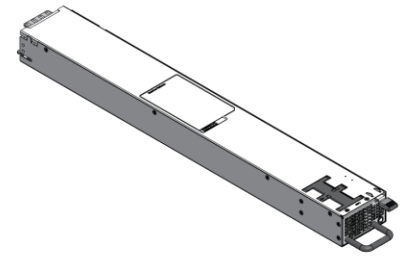

TOP SIDE



BOTTOM SIDE



1. This drawing is a graphical representation of the product and may not show all fine details such as molded part surface features, internal components, screw head type. Please contact Murata for 3D model for additional details
2. Dimensions in mm
3. Latch Cover Colour: Pantone 654C (Blue)
4. Subject to change without notice; contact factory for latest version

OPTIONAL ACCESSORIES

Part Number	Description
MWOCP68-CONC	Single power supply, output, and signal break-out connector board

APPLICATION NOTES

Document Number	Description	Click link below to open online document
ACAN-104	Output Connector Card	Link to: Document
ACAN-141	MWOCP68-3600-B-RM PMBus™ Protocol	Link to: Document

Murata Power Solutions, Inc.
129 Flanders Rd. Westborough,
Ma 01581, USA.
ISO 9001 REGISTERED



This product is subject to the following operating requirements and the Life and Safety Critical Application Sales Policy: Refer to:

<https://www.murata.com/requirements/>

Murata Power Solutions, Inc. makes no representation that the use of its products in the circuits described herein, or the use of other technique information contained herein, will not infringe upon existing or future patent rights. The descriptions contained herein do not imply the granting of licenses to make, use, or sell equipment constructed in accordance therewith. Specifications are subject to change without notice

©2023 Murata Power Solutions, Inc