

### PRODUCT OVERVIEW



MWOCP68-3600-D-RM is a highly efficient 80PLUS® Titanium certified 3,600-Watt power factor corrected front-end power module that provides a 54.5Vdc main and a 12Vdc standby output. Active Current Sharing capability enables operation of multiple power modules within Murata's [Open Compute compliant shelves](#), ensuring current and future power requirements are met. Up to 21.6kW (18kW in N+1 configuration) of output power can be provided, within a standard 1U, 19-inch rack.

MWOCP68-3600-D-RM Power Supply Modules can be hot-swappable, recover from over-temperature faults, provides hardware status LEDs, status signals, and includes PMBus™ 1.2 digital communication capability. The low profile 1U package and 44.3 W/in<sup>3</sup> power density make this series ideal for deployment in OCP open rack architecture or stand-alone applications requiring high reliability and maximum uptime.

### FEATURES:

- 80 Plus® Titanium Certified
- Black-Box data-logging feature
- HVAC / HVDC input operation (180-305Vac, 192-400Vdc)
- 54.5Vdc 66A main output
- 12V 2.5A standby output
- Nominal Dimensions:
  - 68.0mm (W) x 490.0mm (L) x 40.0mm (H)
  - 2.68" (W) x 19.29" (L) x 1.57" (H)
- 44.3 Watts per cubic inch density (W/in<sup>3</sup>)
- N+1 redundancy including hot swap capability, up to 6 power modules
- Integral ORing MOSFETS, both outputs
- Active current sharing main output, Droop current sharing for 12VSB output
- Internally cooled by advanced dual rotor variable speed-controlled fan
- PMBus™ / I<sup>2</sup>C interface monitoring, configuration and control
- RoHS2 compliant
- PCB card edge fingers provided for incoming voltage source connection and DC output in "double-decked" configuration
- 2-year warranty

### ORDERING GUIDE

Part Number	Output power @ highline (180-300Vac & 192-400Vdc)	Main Output	Standby Output	Airflow
MWOCP68-3600-D-RM	3600W	54.5Vdc	12.0Vdc	Front to Back

### INPUT CHARACTERISTICS

Parameter	Conditions	Min	Typ.	Max	Units
Input Voltage Operating Range	AC Voltage	180	230/277	305	Vac
	AC Line Frequency	47	50/60	63	Hz
	DC Voltage	192	240/380	400	Vdc
Turn-on Voltage	AC (Ramp-up)	179	182	185	Vac
	DC (Ramp-up)	182	186	190	Vdc
Turn-off Voltage	AC (Ramp-down)	168	171	174	Vac
	DC (Ramp-down)	172	176	180	Vdc
Maximum Input Current	Vin; 180Vac; 3600W			23.5	Arms
	Vin; 180Vdc; 3600W			23.0	Adc
Inrush Current	Cold Start; <200ms			50	Apk
Power Factor <sup>1</sup>	230 Vac; FL		0.99		W/VA
Efficiency (Excluding Fan Load)	230Vac; 10% FL	90	92.5		%
	230Vac; 20% FL	94	94.5		
	230Vac; 50% FL	96	96.2		
	230Vac; 100% FL	91	94.5		

<sup>1</sup>The power Factor at 20% loading requires to be >0.95 (W/VA) to meet 80 Plus® limits

### OUTPUT VOLTAGE CHARACTERISTICS

Output	Parameter	Conditions	Min	Nom	Max	Units	
54.5V Main	Nominal output voltage			54.5		Vdc	
	Output set point accuracy	230VAC, 50% load, Ta=25°C	54.23	54.5	54.77		
	Line and load regulation		52.87		56.14		
	Ripple voltage & noise <sup>1</sup>	20MHz bandwidth			500		mVpp
	Output current	Across AC & HVDC input ranges	0		66		A
12VSB	Load capacitance		0		10,000	uF	
	Nominal output voltage			12.0		Vdc	
	Output set point accuracy	50% load, Ta=25°C	11.94		12.06		
	Line and load regulation		11.64		12.36		
	Ripple voltage & noise <sup>1</sup>	20MHz bandwidth			240		mVpp
Output current		0		2.5	A		
	Load capacitance		100		3,100	uF	

<sup>1</sup> Ripple and noise measured with a parallel combination of 0.1uF ceramic and 10uF low ESR capacitors on the power module respective output. A short coaxial cable connected directly to the input of a scope is required.



For full details go to [www.murata.com/rohs](http://www.murata.com/rohs)



OUTPUT CHARACTERISTICS					
Parameter	Conditions	Min	Typ.	Max	Units
Startup Time	From application of the AC source to turn on of Main 54.5V			2	sec
Transient Response	54.5V main, 50% load step within range of 10% to 100%, 1A/us di/dt, recovery within 2ms	-2725		+2725	mVpp
	12VSB, 50% load step within range of 10% to 100%, 1A/us di/dt, recovery within 500us	-600		600	
54.5V main output current sharing accuracy (module to module deviation) up to 6 modules in parallel	Percentage of total host system load current / number sharing units	50% to 100% Load		5	%
		20% to <50% Load		10	
Hot Swap Transients	All outputs remain within regulation band	-5		5	
Holdup Time	3600W Load	12			ms
	1800W Load	20			

ENVIRONMENTAL CHARACTERISTICS					
Parameter	Conditions	Min	Nom	Max	Units
Storage temperature range		-40		70	°C
Operating temperature range <sup>1</sup>	Altitude < 1,880m (6167 ft)	0		50	°C
	Altitude < 3,000m (9842 ft)	0		40	
Operating humidity	Non-condensing	5		95	%
Storage humidity	Non-condensing	5		95	%
System back pressure tolerance (Target: Module P-Q curves to be provided)		0.5/125			in-H <sub>2</sub> O/Pa
MTBF (Target)	Per Telcordia SR-332 issue 3 M1C3 @ 40°C & 230Vac	300k			hrs
Shock	10G shock without degradation of performance or mechanical damage to components in operational 30G in non-operational condition Validation testing per IEC60068-2-27; test Ea. 30G, 11msec half-sine, 3 shocks per face, 6 faces.				
Operating vibration	Sine sweep; 5-150Hz, 0.78G; Random vibration, 5-500Hz, 0.78G				
Safety approval	UL62368-1: 2014 (2nd Edition) (Information Technology Equipment – safety - Part 1: General Requirements) CAN/CSA-C22.2 No. 62368-1: 2014 (2nd Edition) (Information Technology Equipment - Safety - Part 1: General Requirements) TUV: EN 62368-1:2014 (2nd Edition) CQC: GB4943.1-2011 BSMI: CNS14336-1 EAC: IEC 60950-1:2005, AMD1:2009, AMD2:2013 CB: IEC 60950-1:2005, AMD1:2009, AMD2:2013 CB: IEC 62368-1:2014 (2nd Edition)				
Input fuse	Dual internal fuses 25A/500V fast blow on the AC line and neutral input connections				
Weight					2.1kg (4.63 lbs.)

<sup>1</sup> Sufficient safety creepage/clearance is provided to allow operation at this altitude however performance may be impacted due to back-pressure imposed by host/system.

PROTECTION CHARACTERISTICS						
Parameter	Conditions		Min	Nom	Max	Units
Over temperature (intake)	Auto restart		50		60	°C
<b>54.5V OCP Condition<sup>2</sup></b>	<b>180-305V<sub>AC</sub></b>	<b>192-400V<sub>DC</sub></b>	<b>SMBALERT Delay</b>		<b>PSU Fault Delay</b>	
OCP Warning Threshold	70.0 A ± 5%	70.0 A ± 5%	20 sec		None	
OCP1 threshold	76.6 A ± 5%	76.6 A ± 5%	20 sec		>20sec +100ms	
OCP2 threshold	87 A ± 10%	87 A ± 10%	<15ms		>20ms	
SCP threshold	>94 A	>94 A	Immediately		Immediately	
<b>12VSB OCP Condition</b>	<b>180-305V<sub>AC</sub></b>	<b>192-400V<sub>DC</sub></b>	<b>SMBALERT Delay</b>		<b>PSU Fault Delay</b>	
OCP1 threshold	3.5 A ± 10%	3.5 A ± 10%	None		>20 sec <sup>1</sup>	
OCP2 Threshold	> 4.0A	> 4.0A	None		Immediately <sup>1</sup>	

<sup>1</sup> The 12VSB OCP protection shall be non-latching

<sup>2</sup> repetitive overcurrent conditions (e.g. at reduced duty cycle) may be limited by thermal performance and protected by OTP accordingly

Overvoltage Protection (OVP)						
Input	Condition	Action	Min	Nom	Max	Units
54.5V Main	Overvoltage	Latching, recycling AC source or toggle PS_ON to reset	57.0	58.5	59.5 <sup>1</sup>	Vdc
12VSB	Overvoltage	Latching, recycling AC source to reset	13		15	Vdc

<sup>1</sup> Shall preserve SELV limit

ISOLATION CHARACTERISTICS						
Parameter	Conditions		Min	Nom	Max	Units
Insulation safety rating / test voltage	Input to output - Reinforced		3,000			Vrms
	Input to chassis - Basic		1,500			
Isolation	Output return to chassis		60			Vdc

EMISSION AND IMMUNITY			
Characteristics	Standard	Criteria	
Input current harmonics	IEC/EN 61000-3-12	Complies with Class A Limits	
Voltage fluctuation and flicker	IEC/EN 61000-3-11	Complies	
Conducted emission	FCC47 CFR part15/CISPR 22/EN55032	Class A with 6dB margin	
ESD immunity	IEC/EN 61000-4-2	Level 4 criteria A	
Radiated field immunity	IEC/EN 61000-4-3	Level 3 criteria B	
Electrical fast transient/burst immunity	IEC/EN 61000-4-4	Level 3 criteria B	
Surge immunity	IEC/EN 61000-4-5	Level 3 criteria A	
RF conducted immunity	IEC/EN 61000-4-6	Level 3 criteria A	
Magnetic field immunity	IEC/EN 61000-4-8	3A/m criteria B	
Voltage dips, interruptions	IEC/EN 61000-4-11	230Vin, 100% load, phase 0°, dip 100% duration 10ms (A) 230Vin, 50% load, phase 0°, dip 100% duration 20ms (54.5V main: B, 12VSB: A) 230Vin, 100% load, phase 0°, dip 100% duration >20ms (B)	

RELATED PRODUCTS		
Model	Function	Description
MWOCES-191-M-B	OCP Power Shelf	19" x 1RU up to 21.6kW OCP Compliant Power Shelf comprised of the Power Shelf, 6PSUs, 1 RMU with optional Automatic Transfer Switches

**OUTPUT CHARACTERISTICS; PEAK LOAD PROFILE**

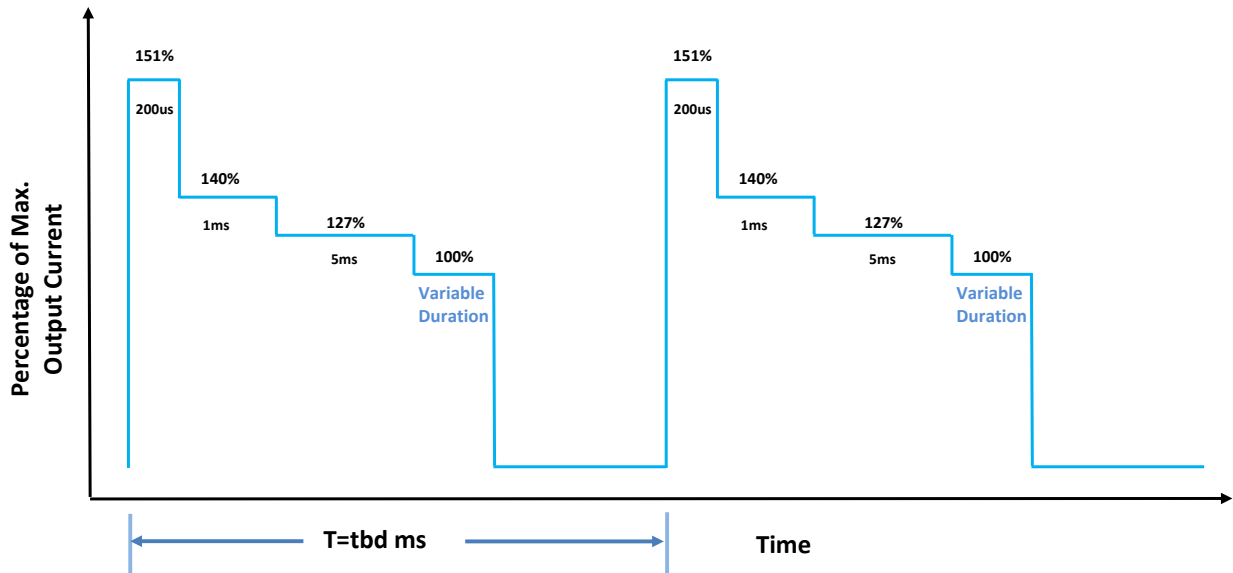

The above profile illustrates the power module's peak repetitive load operating capability and the output should not shut down under these conditions. The power module should not be operated continuously at load conditions that exceed the product's safety ratings.

STATUS AND CONTROL SIGNALS		
Signal Name	Description	Interface Details
12V main_REMOTE_SENSE& 12V main_REMOTE_SENSE_RETURN	The remote sense signals are intended can be connected at point of load. The power module senses this remote output voltage and can compensate for up to 0.25Vdc of voltage drop due to resistive losses caused by the load current and associated connection. For best performance, the remote sense lines should be routed away from noise sourced and be twisted together if using a harness.	
VIN_GOOD	This active high signal Indicates incoming source voltage (AC or DC) is valid	Link to <a href="#">interface details</a>
PWOK	Power Okay signal Indicates all outputs are valid and without faults	Link to <a href="#">interface details</a>
SMBALERT_L	This signal asserts (low state) to indicate to the host/system that a fault condition has been detected within the power module. This signal asserts coincident with the setting of any supported PMBus™ status_x register fault bit flags. Refer to <a href="#">ACAN-109</a> for details	Link to <a href="#">interface details</a>
SCL, SDA	Clock (SCL) and data (SDA) serial digital lines, compatible with PMBus™ Power Systems Management Protocol Part 1 – General Requirements Rev 1.2 and includes 45p internal capacitance.	Link to <a href="#">interface details</a>
SIGNAL_RETURN	Signal return is the reference point for all signals and is separate from the main output return.	signal ground must be externally connected to 12VSB_RETURN (at system side)
I_SHARE	This signal is connected between sharing units forming a current share bus. It is an input and/or an output (bi-directional analog bus) as the voltage on the line controls the current share between sharing units. A power module will respond to a change in this voltage and a power supply can also change the voltage depending on the load drawn from it. On a single unit, the voltage on the pin (and the common ISHARE bus) would read approximately 8VDC at 100% load (single power module capability). For two identical units sharing this same 100% load this would read approximately 4VDC for perfect current sharing (i.e. 50% module load capability per power module).	
12VSB_RETURN	Standby output return is an independent return for the signal reference and is internally connected to VSB Return and Main Output Return.	signal ground must be externally connected to 12VSB_RETURN (at system side)
PSKILL	This signal is used for internal power module power processing to ensure glitch free operation during power module insertion or extraction into/from host/system and is internally pulled up. This signal must be connected to signal return at system side and is provided on shortest pin (last to make, first to break contact). The main 12V output is enabled upon detecting the low state and disabled when a low state is no longer detected.	Link to <a href="#">interface details</a>
PS_ON_L	Provides remote on/off control of the main 12V output. This signal in internally pulled up. The main output is turned on when this signal is externally connected to signal return and off when not connected to signal return.	Link to <a href="#">interface details</a>
PS_A2	PMBus™ address selection for power module; Short either pins to signal return set the address line to logic Low to set hardware slave address. Open or pull up externally set the pin to logic High. PS_A2 is the most significant bit. Refer to <a href="#">ACAN-109</a> for details.	Link to <a href="#">interface details</a>
PS_A1		
PS_A0		
PRESENT	The signal is used to detect the presence (installation) of a power module by the host system.	Link to <a href="#">interface details</a>

### TIMING SPECIFICATIONS

Time Reference	Description	Min	Max	Units
T1	Delay from 12V <sub>SB</sub> regulation to 54V <sub>DC</sub> output turn on.	5	500	ms
T2A	Main 54V <sub>DC</sub> rise time	2	100	ms
T2B	12V <sub>SB</sub> rise time	2	20	ms
T3	Delay from Main 54V <sub>DC</sub> output within regulation to PWOK assertion at turn on	100	500	ms
T4	Delay from PWOK de-assertion to Main 54V <sub>DC</sub> dropping out of	1		ms
T5	Delay from Main 54V <sub>DC</sub> out of regulation to 12V <sub>SB</sub> turn off.	5		ms
T6	Delay from loss of INPUT to PWOK de-assertion	10		ms
T7	Delay from application of INPUT on to Main 54V <sub>DC</sub> turn on		2000	ms
T8	PS_ON negation (PSU off) to PWOK negation		2	ms
T9	PS_ON (PSU on) to output established		350	ms
T11	Delay from VIN drop out to VIN_GOOD negation & SMBALERT assertion		2	ms
T12	Delay from VIN GOOD to PWOK	1		ms

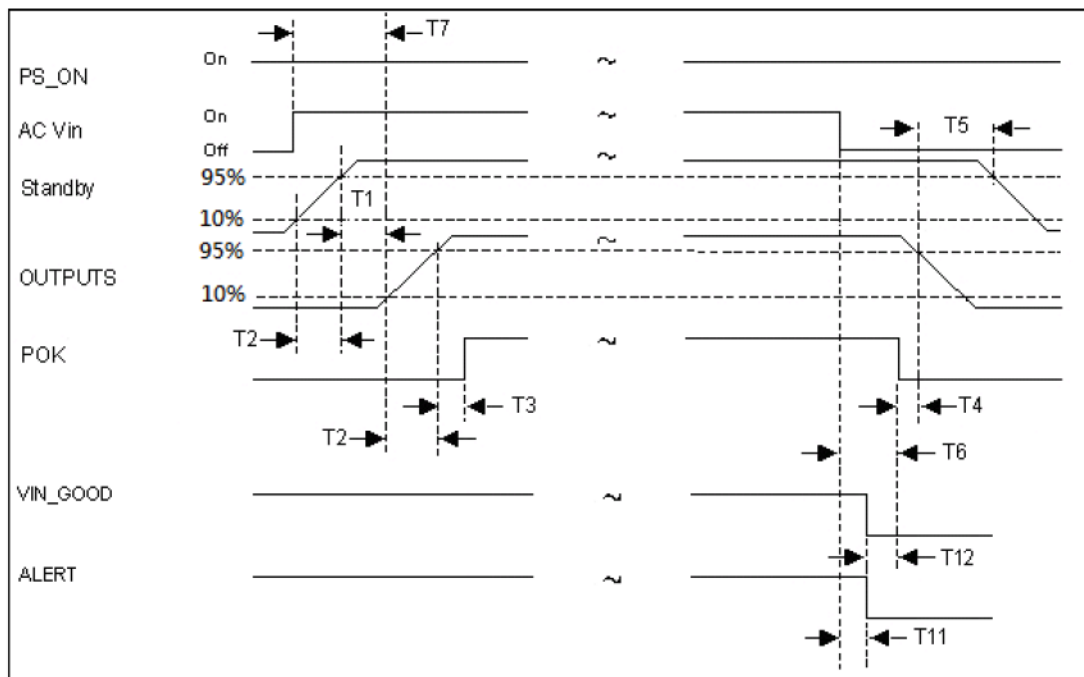

## INPUT, OUTPUT, SIGNAL INTERFACE DETAILS

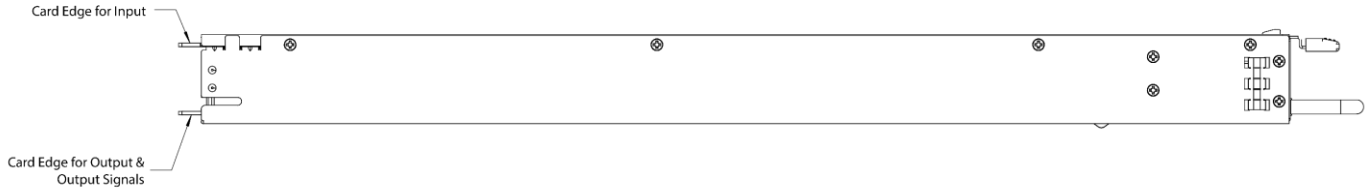

### Power Supply module Side: INPUT CARD EDGE:

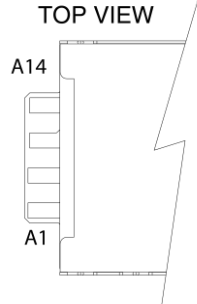

### Power Supply module Side: OUTPUT CARD EDGE:

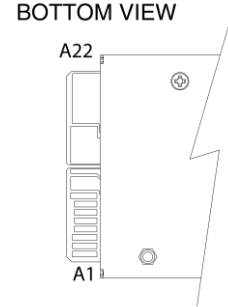

### Mating Connector (System Side) FCI 10035388 Series

#### FCI Dimensions

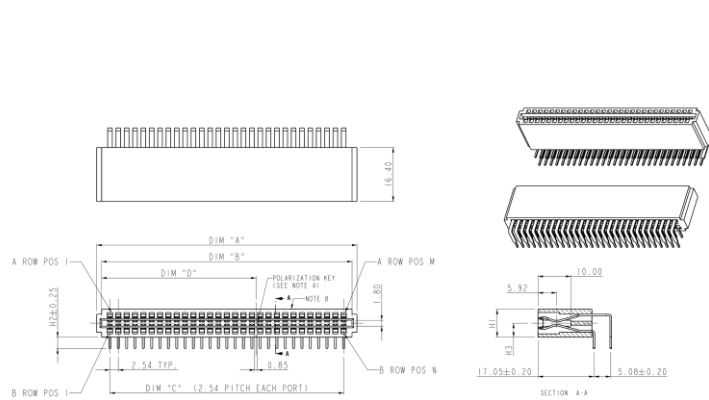

#### FCI Recommended PCB Layout

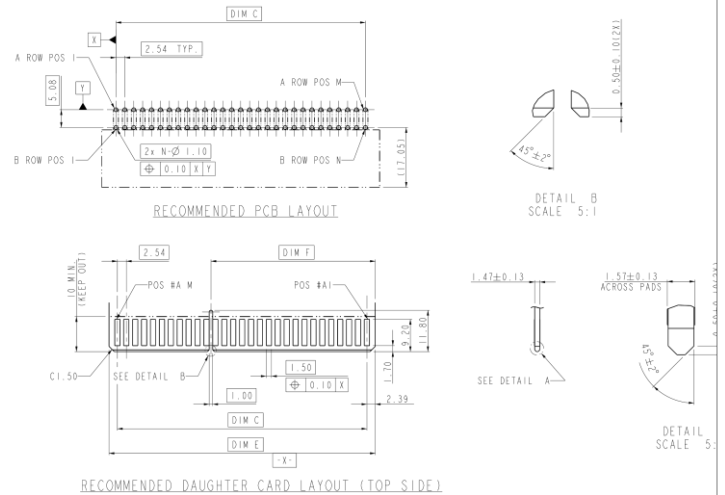

<sup>1</sup> FCI details about shown for illustration purposes; refer to the FCI's connector datasheet for fine details and specifications

### Mating Connector (System Side): FCI Power Edge Card Series:

### Mating Connector (System Side): FCI Power Edge Card Series:

PRAT NO.	DIM"A"	DIM"B"	DIM"C"	DIM"D"	DIM"E"	DIM"F"	H1	H2	H3	PIN CONFIGURATION	M	N
10035388-12 10035388-12ELF	41.10	38.10	33.02	N/A	37.80	N/A	8.50	3.50	4.25	41 POS: 20PWR, 12SIGNAL 41 POS: 20PWR, 12SIGNAL	14	14

PRAT NO.	DIM"A"	DIM"B"	DIM"C"	DIM"D"	DIM"E"	DIM"F"	H1	H2	H3	PIN CONFIGURATION	M	N
10035388-400 10035388-400LF	61.42	58.42	53.34	29.21	58.12	29.06	8.50	3.50	4.25	ALL LOADED	22	22

**INPUT POWER INTERFACE CARD EDGE "GOLD FINGER" PIN ASSIGNMENT**

Signal	No. of pins	Pin assignment	Description
NEUTRAL	4	A13-A14 / B13-B14	Incoming Neutral/L2 or HVDC connection; Dual fusing allows for phase connection of suitable voltage rating
LIVE Line/L1/HVDC	4	A9-A10 / B9-B10	Incoming line/phase or HVDC connection; Dual fusing allows for phase connection of suitable voltage rating
PE	8	A1, 2, 5, 6 / B1, 2, 5, 6	Protective earth; connects to enclosure/chassis

**OUTPUT, SIGNAL INTERFACE CARD EDGE "GOLD FINGER" PIN ASSIGNMENT**

Signal	No. of pins	Pin Location	Description
12VSB	2	B9, B10	12V "Standby"; 12VSB "+VE" output connection
I_SHARE	1	B6	An active analogue current share "bus" directly connected between sharing power modules
REMOTE_SENSE_RETURN	1	B7	Compensation of voltage drops caused by resistive losses to the load
12VSB_RETURN	2	A9, A10	12V "standby Return"; 12VSB_RETURN & SIGNAL_RETURN must be shorted together at system side
REMOTE_SENSE	1	B8	Compensation of voltage drops caused by resistive losses to the load
PSKILL	1	A4	Power module kill pin; used during insertion and extraction during "hot swap" of the power module; shortest sequenced pin, Last to Make, First to Break (LMFB) contact
VIN_GOOD	1	A2	Input source voltage present and within operational limits
PS_ON_L	1	A3	Remote ON/OFF (enable/disable) of the 54.5V Main output
PWOK	1	A1	All outputs are present valid and exhibit no faults (within operational limits)
SMBALERT_L	1	B2	An alert (interrupt) issued to the host system in response to a warning of fault condition raised in the power module
PS_A2	1	B3	I2C bits to allow addressing of slave devices operating on the PMBus™ (Power Management Bus protocol).
PS_A1	1	B4	
PS_A0	1	B5	
SCL	1	A7	
SDA	1	A6	Serial clock (SCL) and data (SDA) lines use for communication with slave PMBus™ slave devices
SIGNAL_RETURN	1	A8	A signal ground (common) for all signals (including I2C); note that this signal must be directly connected to 12VSB_RETURN at the system connector
PRESENT	1	A5	A passive signal directly connected internally within the power module to SIGNAL_RETURN
54.5V MAIN_OUTPUT	12	A17-A22, B17-B22	The positive terminal of the main output
54.5V MAIN_RETURN	12	A11-A16, B11-B16	The return terminal of the main output

### MECHANICAL DIMENSIONS

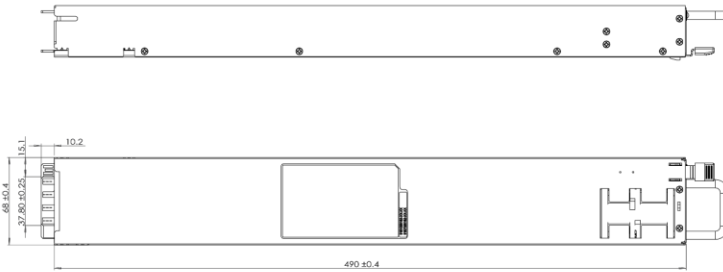
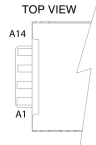
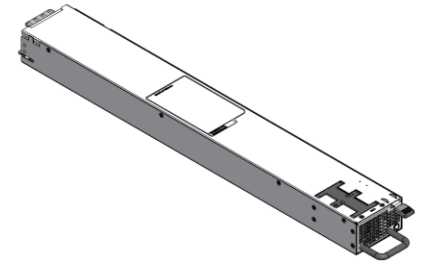

TOP SIDE



BOTTOM SIDE



BOTTOM VIEW



1. This drawing is a graphical representation of the product and may not show all fine details such as molded part surface features, internal components, screw head type. Please contact Murata for 3D model for additional details
2. Dimensions in mm
3. Latch Cover Colour: Pantone 654C (Blue)
4. Subject to change without notice; contact factory for latest version

### OPTIONAL ACCESSORIES

Part Number	Description
MWOCP68-CONC	Single power supply, output and signal break-out connector board

### APPLICATION NOTES

Document Number	Description	Click link below to open online document
ACAN-104	Output Connector Card	Link to: <a href="#">Document</a>
ACAN-114	MWOCP68-3600-D-RM PMBus™ Protocol	Link to: <a href="#">Document</a>

Murata Power Solutions, Inc.  
129 Flanders Rd. Westborough, Ma 01581, USA  
ISO 9001 REGISTERED



This product is subject to the following operating requirements and the Life and Safety Critical Application Sales Policy:

Refer to:

<https://www.murata.com/products/power/requirements/>

Murata Power Solutions, Inc. makes no representation that the use of its products in the circuits described herein, or the use of other technical information contained herein, will not infringe upon existing or future patent rights. The descriptions contained herein do not imply the granting of licenses to make, use, or sell equipment constructed in accordance therewith. Specifications are subject to change without notice. © 2023 Murata Power Solutions, Inc.